



# MPL 3.5

Scissors Lift

## Original Operating Instructions

BA082701-en



Lifting Technology



DIN EN ISO 9001:2008  
ISO 14001:2004

SINCE 1969



Premium Workshop  
Equipment

## Contents

<b>1</b>	<b>Safety .....</b>	<b>3</b>
1.1	Introduction .....	3
1.2	Symbols .....	3
1.3	Intended Use .....	3
1.4	Safety Instructions for Commissioning .....	3
1.5	Safety Instructions for Operation .....	4
1.6	Safety Instructions for Servicing .....	4
<b>2</b>	<b>Specifications .....</b>	<b>5</b>
<b>3</b>	<b>Operation .....</b>	<b>6</b>
3.1	What to Do in the Event of Defects or Malfunctions .....	6
3.2	Main Switch .....	6
3.3	Controls .....	7
3.4	Raising and Lowering .....	8
3.5	Protection against Unauthorized Usage .....	8
3.6	Bleeding the Hydraulic System .....	9
3.7	Manual Lowering .....	9
3.8	Transverse Beam .....	10
<b>4</b>	<b>Maintenance .....</b>	<b>12</b>
4.1	Maintenance Schedule .....	12
4.2	Annual Inspection .....	12
4.3	Refilling with Hydraulic Fluid .....	13
4.4	Cleaning .....	13
<b>5</b>	<b>Troubleshooting .....</b>	<b>14</b>
<b>6</b>	<b>Company Information .....</b>	<b>15</b>

---

# 1 Safety

## 1.1 Introduction

Thoroughly read this manual before operating the equipment and comply with the instructions. Always display the manual in a conspicuous location.

Personal injury and property damage incurred due to non-compliance with these safety instructions are not covered by the product liability regulations.

## 1.2 Symbols



Important safety instructions. Failure to comply with instructions could result in personal injury or property damage.

---



Important information.

---

## 1.3 Intended Use

- This lift shall be used exclusively for the safe lifting of motor vehicles. Observe the rated load capacity.
- The lift shall not be modified without the express written consent of the manufacturer. In case of non-compliance the declaration of conformity becomes void.

## 1.4 Safety Instructions for Commissioning

- The lift shall be installed and commissioned by authorized service personnel only.
- The control desk shall not be installed in the danger zone of the lift.
- The standard lift version shall not be installed and commissioned in hazardous locations, outdoors or in moist rooms (e.g. car wash).

## 1.5 Safety Instructions for Operation

- Read the detailed operating manual.
- Lift operation by trained personnel over 18 years only.
- Drive on the lift only when it is in bottom position.
- Ensure an unobstructed movement of lift and vehicle.
- After raising the vehicle briefly, stop and check the lift supports for secure contact.
- Make sure the vehicle doors are closed during raising and lowering cycles.
- Closely watch lift and vehicle during raising and lowering cycles.
- Do not allow anyone to stay in lift area during raising and lowering cycles.
- Do not allow anyone to climb up the lift or the raised vehicle.
- Comply with the applicable accident prevention regulations.
- Do not exceed the rated load capacity as indicated on the lift nameplate.
- Only use the vehicle manufacturer's recommended lift points.
- Do not use the lift for transporting persons.
- After positioning the vehicle on the lift secure it against roll-off.
- Keep lift and vehicle free of tools and parts.
- Keep the lift and lift area clean.
- The main switch serves as emergency switch. In case of emergency turn it to position "0".
- Protect all parts of the electrical equipment from humidity.
- Protect the lift against unauthorized usage by padlocking the main switch.
- Use caution with operating vehicle engines. Danger of poisoning!

## 1.6 Safety Instructions for Servicing

- Service work may be done by authorized service technicians only.
- Turn off and padlock the main switch before doing any repair, maintenance or setup work.
- Work on pulse generators or proximity switches may be done by authorized service technicians only.
- Work on the electrical equipment may be done by service technicians or certified electricians only.
- Ensure that ecologically harmful substances are disposed of only in accordance with the appropriate regulations.
- Do not use high pressure or steam jet cleaners. Do not use caustic cleaning agents.
- The lift's safety devices must be set by authorized service technicians.
- Do not replace or override the safety devices.

## 2 Specifications

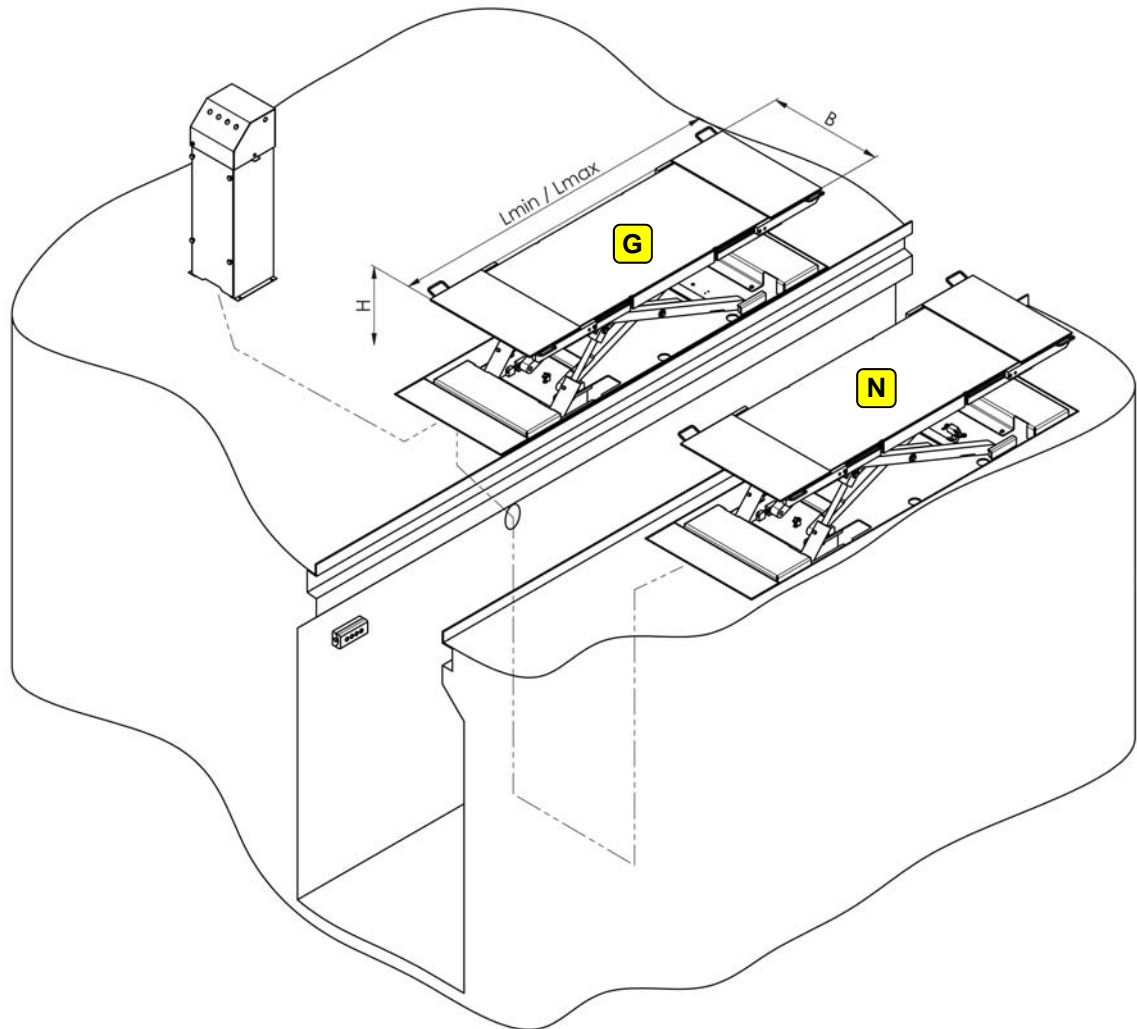

**G** Master side

**N** Slave side

	<b>MPL 3.5</b>
Load capacity	3500 kg
Lifting height H	450 mm
Width of support plate B	683 mm
Overall length Lmin...Lmax	1500...2008 mm

## 3 Operation

---



- Lift operation by trained personnel over 18 years only.
  - Do not exceed the rated load capacity as indicated on the lift nameplate.
  - Do not allow anyone to stay in lift area during raising and lowering cycles.
  - Closely watch lift and vehicle during raising and lowering cycles.
  - Make sure the vehicle doors are closed during raising and lowering cycles.
  - The lift area which cannot be seen by the operator during raising and lowering cycles must be observed by a second person.
  - After raising the vehicle briefly, stop and check the lift supports for secure contact with the vehicle.
  - Do not allow anyone to climb up the lift or the raised vehicle.
- 

### 3.1 What to Do in the Event of Defects or Malfunctions

---



- In case of defects or malfunctions such as uncontrolled lift movement or deformation of the superstructure, support or lower the lift immediately.
  - Turn off the main switch and secure it against unauthorized usage. Contact service.
- 

### 3.2 Main Switch

---



The main switch is used as emergency switch. In case of emergency turn it to position 0.

---

- Main switch in position 0: Power supply is interrupted
- Main switch in position 1: Lift is ready for operation

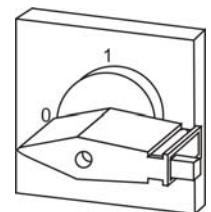

### 3.3 Controls

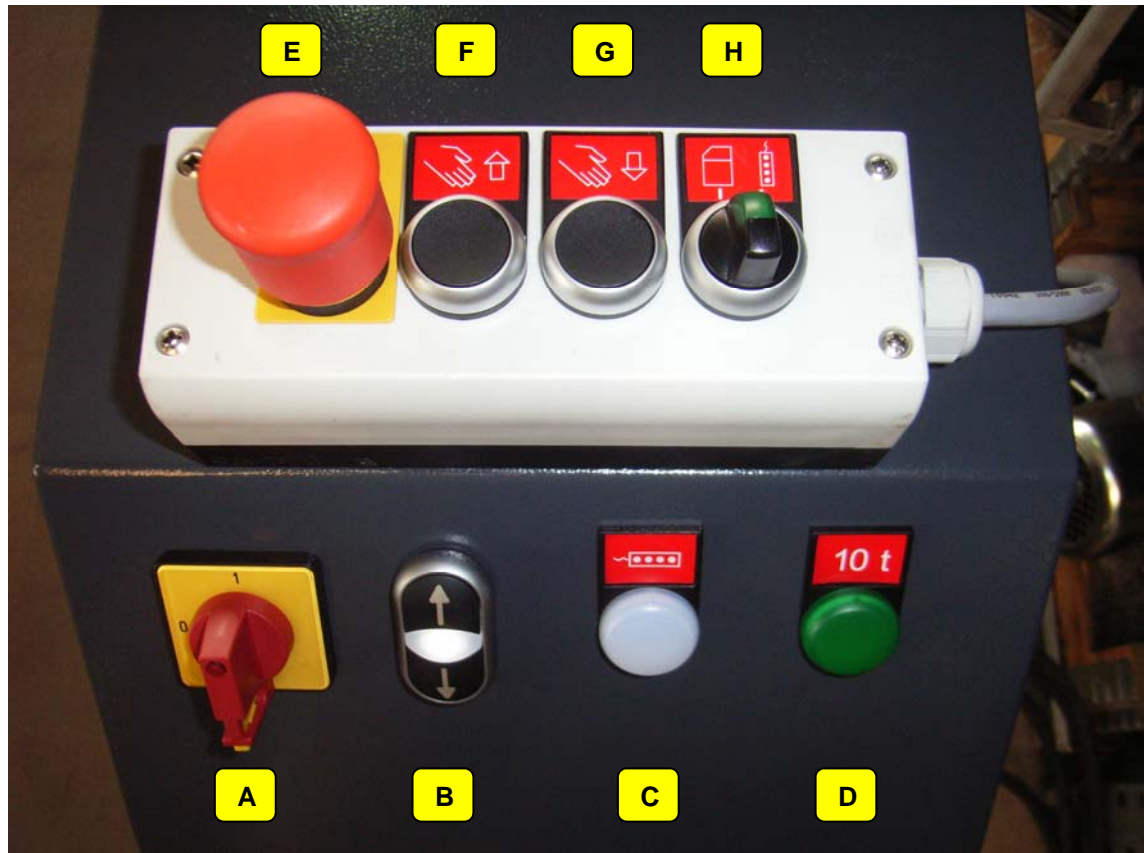

#### Control desk

- A** Main switch
- B** Double button RAISE / LOWER
- C** Indicator lamp "Remote control active"
- D** Indicator lamp "10 t axle load, traversable"

#### Remote control

- E** Emergency Off Key
- F** Button RAISE
- G** Button LOWER
- H** Selector switch Control desk/Remote control



- When the remote control is enabled ( $\Rightarrow$  indicator lamp **C** lighting up), double button **B** is disabled.
- Main switch and emergency stop button are permanently enabled.

### 3.4 Raising and Lowering



Make sure the vehicle is lifted symmetrically!

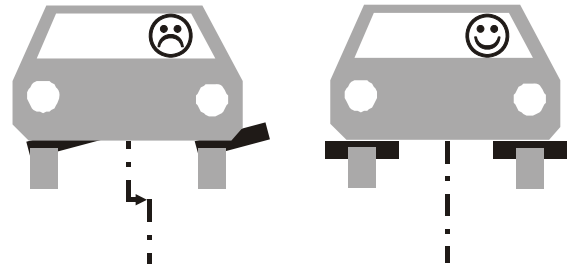

- 1 Turn the main switch to position 1.  
⇒ Lift is ready for operation.
- 2 Choose the operating unit (control desk or remote control) using the selector switch. The white indicator lamp lights up when the remote control is enabled.
- 3 Push and hold RAISE button until lift reaches desired height.  
⇒ Lift stops once button is released or upper limit stop is reached.
- 4 Push and hold LOWER button until lift reaches desired height.  
⇒ Lift stops once button is released or CE safety stop is reached.



**Risk of injury!**

Before lowering the lift to bottom position, verify that there are no persons or obstructions in the danger area.

- 4 To lower the lift completely, release the LOWER button and press it again.  
⇒ Lift motion to the lower limit stop is accompanied by an audible signal.



Once the support plates are in bottom position, the lift is traversable with an axle load of 10 t. This status is confirmed by the green indicator lamp.

### 3.5 Protection against Unauthorized Usage



When in position 0, the main switch can be protected against tampering by means of a padlock.

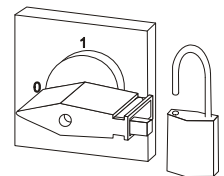



### 3.6 Bleeding the Hydraulic System



Bleeding of hydraulic system is done by authorized service technicians.

### 3.7 Manual Lowering



Authorized personnel only! Do not restart the lift before the error has been remedied.

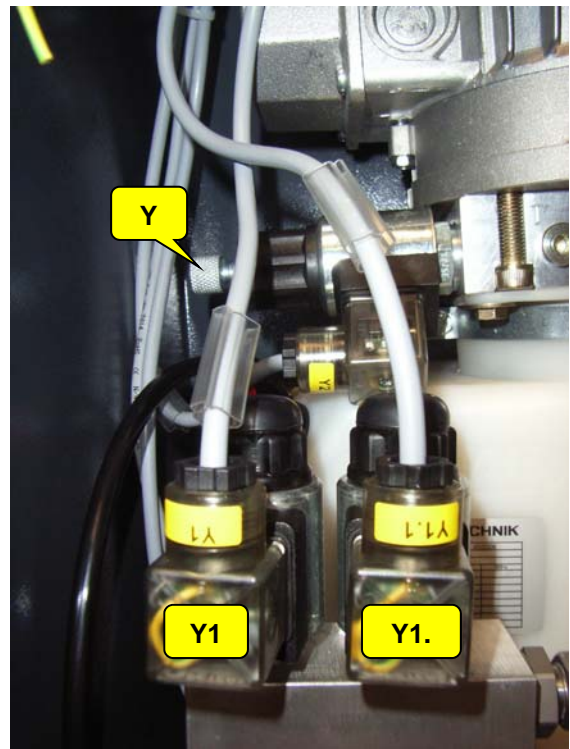

If the lift lowers although valves **Y1** / **Y1.1** are not being actuated, or if the support plates raise and lower unevenly, open the knurled screw at valve **Y2** immediately, shut down the lift and contact the service department.

- 1 Remove the front cover of the control desk.
- 2 Close knurled screw at valve **Y2** .
- 3 Press valves **Y1** and **Y1.1** simultaneously until the lift lowers.
- 4 While lowering, check that both support plates are at the same level.
- 5 As soon as the lift is in bottom position, release valves **Y1** and **Y1.1** and open the knurled screw at valve **Y2**.

### 3.8 Transverse Beam

#### Intended Use

The transverse beam is optionally available. It is designed for lifting vehicles whose support points are outside the support range of the lifting unit.

#### Scope of Delivery

Transverse beam (2 pcs.), aluminium, powder coated.

#### Accessories

Support blocks (required):

340 x 132 x 47 mm (VZ 975069) or 340 x 150 x 95 mm (VZ 970045)

#### Important Operating Instructions



- Make sure the transverse beam (A) is positioned symmetrically on the surface of the wheel-free jack (check using yellow marking!).
- Position the support blocks (B) on the antiskid coating.
- Note the colour marking:
  - Yellow (C)** = This section must be positioned **fully** on the support plate of the lifting unit.
  - Black (D)** = Antiskid coating. Engage the vehicle **only** in this section.
  - Red (E)** = Do **not** engage the vehicle in this section.
- Do not exceed rated distances and load capacity (see illustration).

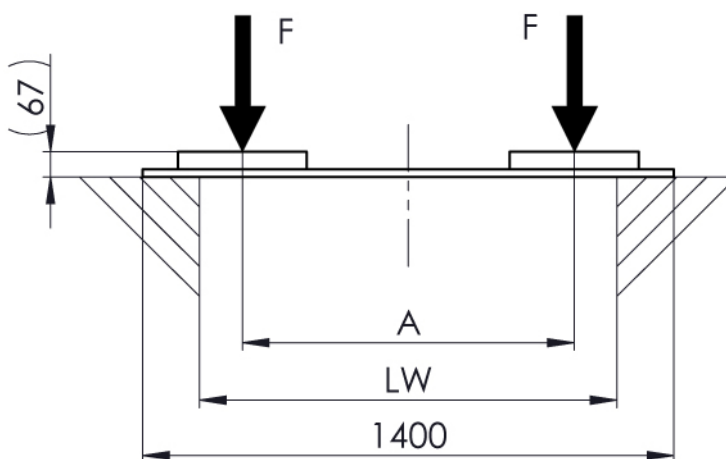

$$A_{\min} = 875 \text{ mm}$$

$$LW_{\max} = 1100 \text{ mm}$$

$$F_{\max} = 750 \text{ kg} \cdot g$$

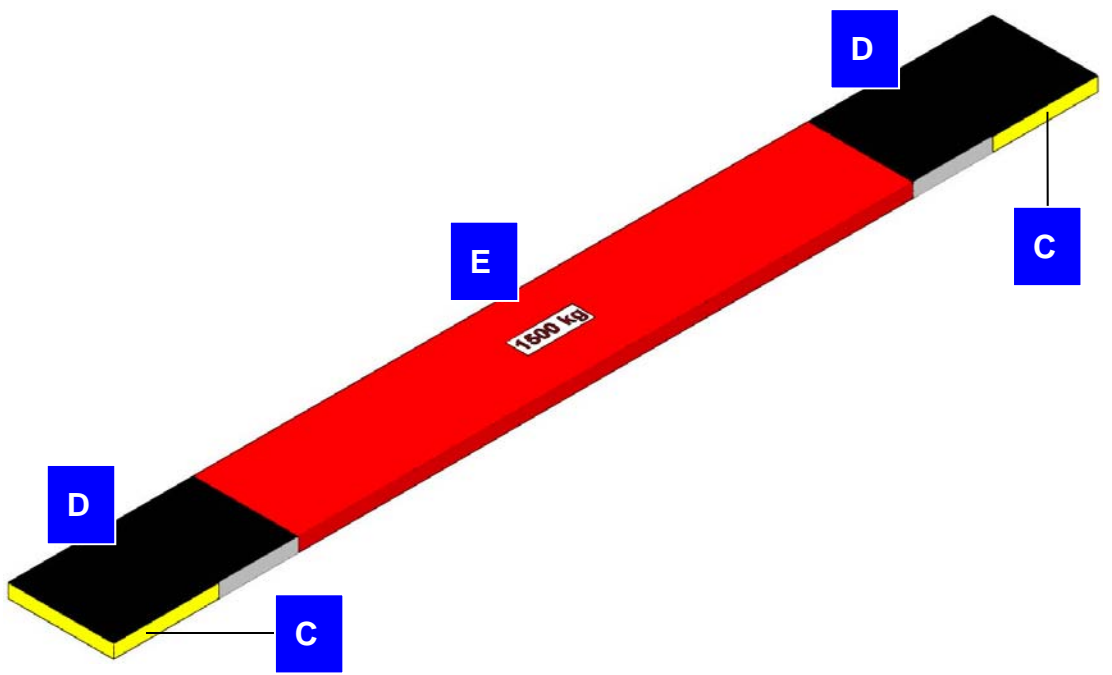
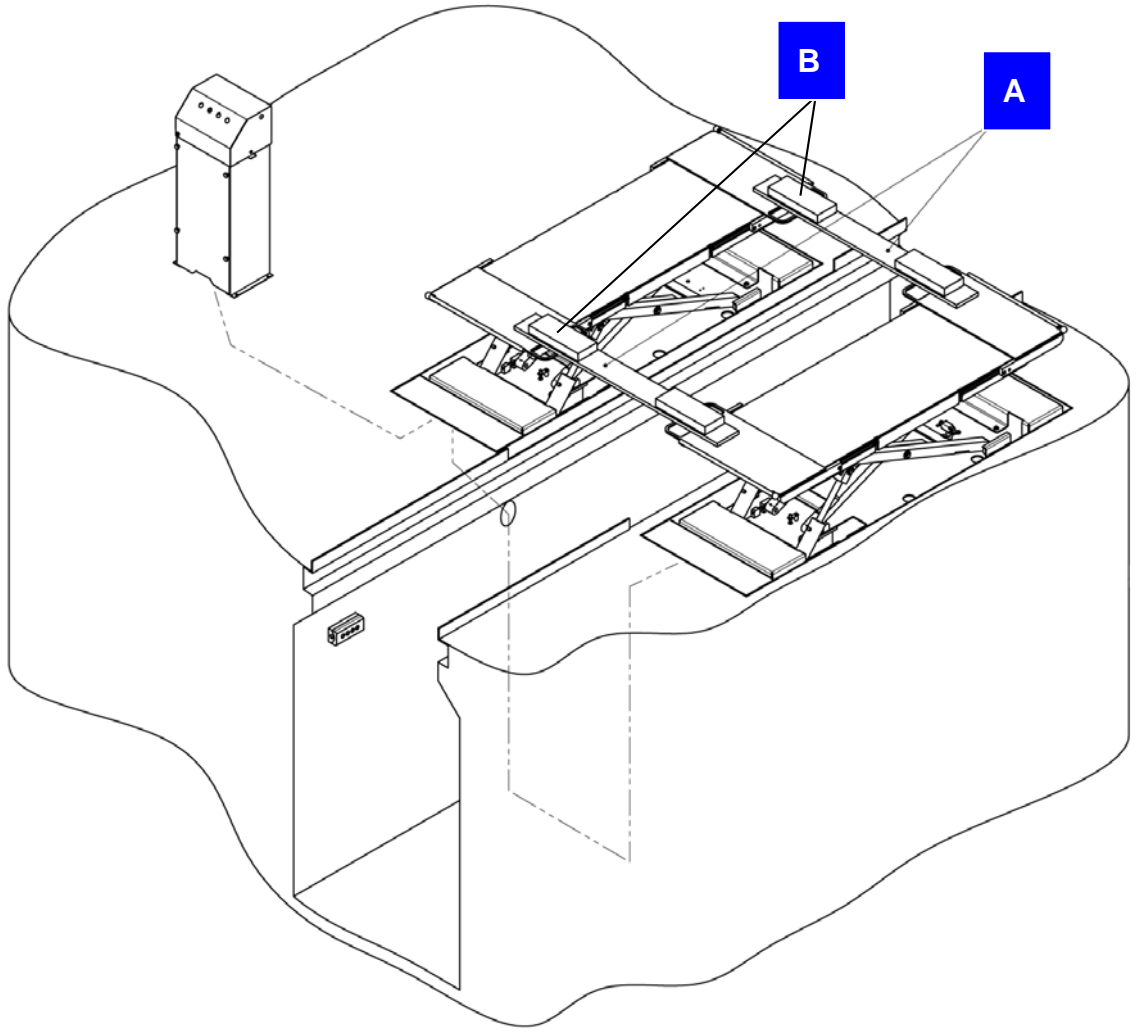

## 4 Maintenance

---



Danger! Electric shock hazard!

Before doing any maintenance work, turn off the main switch and protect it against tampering.

---

### 4.1 Maintenance Schedule

Interval	Maintenance items	Procedure
3 months	Hydraulic system	Check fluid level, refill if necessary.
		Check hydraulic system for tightness.
		Check sealing cups for damage, replace if necessary.
		Check power unit for unusual noise during operation, check fastening screws for tight fit.
6 months	Hydraulic fluid	Check fluid for soiling and aging, replace if necessary.
12 months	General inspection	Check all components for damage.

### 4.2 Annual Inspection

---



- The maintenance interval prescribed by the manufacturer is **12 (twelve) months**. This maintenance interval refers to normal workshop usage. If the equipment is used more frequently or under severe operating conditions (e.g. outdoors), the interval must be reduced accordingly.



- Maintenance work shall be done only by authorized and trained service technicians provided by the manufacturer, licensed dealers or service partners.
  - In case of non-compliance the manufacturer's warranty becomes void.
-

### 4.3 Refilling with Hydraulic Fluid

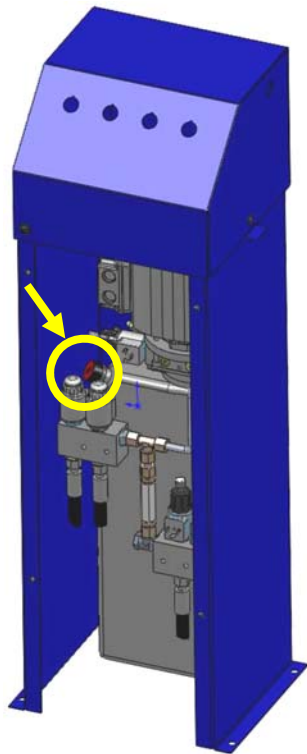

- 1 Check hydraulic fluid level every 3 months with a completely lowered lift.
- 2 Add missing fluid via the filler inlet. Make sure hydraulic fluid meets HLPD 32 specification.



- Replace the hydraulic fluid periodically, depending on aging, soiling and water absorption.
- When topping up, use fluid with the same specification only.
- If the lift is operated permanently at an ambient temperature of  $< 15\text{ }^{\circ}\text{C}$ , use hydraulic fluid with a lower viscosity.
- The pressure hoses should be replaced as required, but after six years at the latest.

### 4.4 Cleaning

Periodically wash off aggressive substances and treat the lift with oil or wax spray.



**Risk of damage!**  
Do not use high pressure or steam jet cleaners. Do not use caustic cleaning agents.

## 5 Troubleshooting

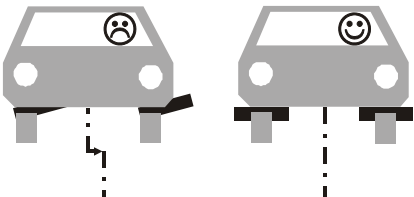
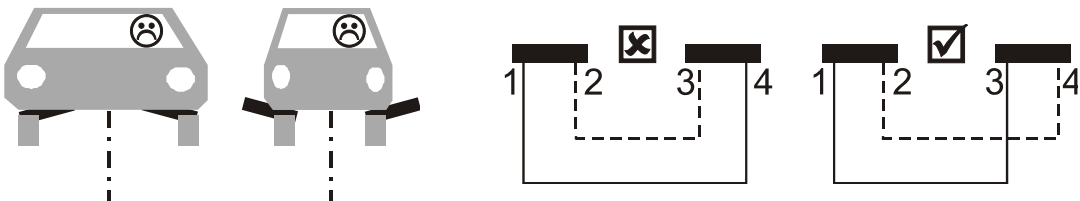
Error	Diagnosis	Remedy
Lift does not run.	Main switch turned off.	Turn on main switch.
	Power failure.	Check for cause of p. failure.
	Power cord interrupted.	Replace defective cord.
	Fuses defective.	Replace fuses.
	Selector switch in wrong position.	Turn switch to correct position.
Lift does not raise.	Reverse motor rotation.	Interchange two phases at main switch.
	Low fluid level.	Top up fluid reservoir.
	RAISE button defective.	Check button and line, replace if necessary.
	Pump intake filter dirty.	Check and clean filter.
	Valve Y2 disabled after manual lowering.	Enable valve Y2 by opening the knurled screw.
Lift capacity insufficient.	Pressure valves maladjusted.	Contact service.
	Pump defective.	
Lift does not lower.	LOWER solenoid valve defective.	Contact service.
	LOWER button defective.	
Support plates lower without control button being pressed.	LOWER solenoid valve does not close completely.	Contact service.
	Leakage in at least two hydraulic lines.	Check connections for tight fit and hoses for damage, replace if necessary.
Lift shows jerky movements.	Air in hydraulic system.	Contact service.
Support plates tilted – in same direction.	Vehicle lifted asymmetrically.	Lift vehicle symmetrically.
		
Support plates tilted – towards outside or inside.	Incorrect cylinder connection.	Contact service to have cylinder connection corrected.
		

## 6 Company Information

© MAHA Maschinenbau Haldenwang GmbH & Co. KG

Legal notice based on ISO 16016:

The reproduction, distribution and utilization of this document as well as the communication of its contents to others without explicit authorization is prohibited. Offenders will be held liable for the payment of damages. All rights reserved in the event of the grant of a patent, utility model or design.

The contents of this edition have been checked with great care. However, errors cannot be fully excluded. Subject to technical change without notice.

### Document

Document №: BA082701-en  
Approval Date: 25.11.2009

### Manufacturer

MAHA Maschinenbau Haldenwang GmbH & Co. KG  
Hoyen 20  
87490 Haldenwang  
Germany

Phone: +49 (0) 8374 585 0  
Fax: +49 (0) 8374 585 590  
Fax Parts: +49 (0) 8374 585 565  
Internet: <http://www.maha.de>  
E-Mail: [maha@maha.de](mailto:maha@maha.de)  
**Hotline:** +49 (0) 180 56242 60 for Brake Testers and Test Lanes  
+49 (0) 180 56242 80 for Automotive Lifts  
+49 (0) 180 56242 90 for Dynamometers and Emission Testers

### Service

AutomoTec GmbH  
Maybachstraße 8  
87437 Kempten  
Germany  
Phone: +49 (0) 180 56242 50  
Fax: +49 (0) 180 56242 55  
Internet: <http://www.automo-tec.com>  
E-Mail: [service@automo-tec.com](mailto:service@automo-tec.com)