



M A H A G R O U P

PMS | LMS

Axle and Joint Play Tester

Original Operating Instructions

BA010101-en

PMS 3.5

PMS 3/D

PMS 3/R

PMS 3/X

PMS 3/XL

PMS 3/D PIT

PMS 3/P PIT

LMS 20.0

LMS 18/1 MTL

LMS 18/2 MTL

BA010101-en
2021-09-17

© MAHA Maschinenbau Haldenwang GmbH & Co. KG

The reproduction, distribution and utilization of this document as well as the communication of its contents to others without explicit authorization is prohibited. Offenders will be held liable for the payment of damages. All rights reserved in the event of the grant of a patent, utility model or design.

The contents of this edition have been checked with great care. However, errors cannot be fully excluded. Subject to technical change without notice.

Manufacturer

MAHA Maschinenbau Haldenwang GmbH & Co. KG
Hoyen 20
87490 Haldenwang
Germany

Phone: +49 8374 585-0
Fax: +49 8374 585-590
Mail: maha@maha.de
Web: www.maha.de

Service

MAHA SERVICE CENTER
Maybachstraße 8
87437 Kempten
Germany

Phone: +49 8374 585-100
Fax: +49 8374 585-491
Mail: service@maha.de
Web: www.mahaservicecenter.de

Contents

1	Safety.....	5
1.1	Introduction.....	5
1.2	Symbols and Signal Words	5
1.2.1	Personal Injury.....	5
1.2.2	Property Damage	5
1.2.3	Information	5
1.3	Intended Use	6
1.4	Requirements on Operating and Service Personnel.....	6
1.5	Safety Instructions for Commissioning.....	6
1.6	Safety Instructions for Operation	6
1.7	Safety Instructions for Servicing.....	7
1.8	Safety Instructions for Handling Hydraulic Fluid	8
2	Transport and Storage.....	8
3	Installation and Initial Operation	9
4	Operation.....	10
4.1	Main Switch.....	10
4.2	Preparing for Operation.....	10
4.3	Operating the Axle Play Detector.....	11
4.4	Operating the Cable Hand Lamp.....	12
4.4.1	LMS 20.0 TL A (Above-Floor) with Cable Hand Lamp	12
4.5	Operating the Radio Hand Lamp RHL (Option).....	13
4.6	Service Mode	13
4.7	Operating Diagrams.....	13
5	Maintenance.....	14
5.1	Maintenance Schedule	14
5.2	Annual Inspection	14
5.3	Maintenance by the Operator.....	15
5.4	Greasing Points	15
5.5	Care Instructions	17
5.6	Spare Parts.....	17
5.7	PMS Variants for Installation on Lift Runways	18
6	Specifications.....	22
6.1	PMS Specifications	22
6.2	LMS Specifications.....	23
7	Dismantling	24
8	Disposal.....	24
9	Contents of the Declaration of Conformity	24
10	Annex: Operating Diagrams	25

[Blank page]

1 Safety

1.1 Introduction

Thoroughly read this manual before operating the equipment and comply with the instructions. Always display the manual in a conspicuous location.

Personal injury and property damage incurred due to non-compliance with these safety instructions are not covered by the product liability regulations.

1.2 Symbols and Signal Words

1.2.1 Personal Injury



DANGER

indicates an immediate hazard which, if not avoided, will result in death or severe personal injury.



WARNING

indicates a potential hazard which, if not avoided, could result in death or severe personal injury.



CAUTION

indicates a potential hazard which, if not avoided, could result in moderate or minor personal injury.

1.2.2 Property Damage

NOTICE

indicates a potentially harmful situation which, if not avoided, could result in damage to the equipment or surrounding objects.

1.2.3 Information



indicates important information notes.

1.3 Intended Use

This device is used exclusively to inspect the axle and joint play of vehicles. Axle play detectors in mobile test lanes are only intended for operation when the lifting device is lowered.

The unit must not be modified without express written permission from the manufacturer. Non-compliance invalidates the declaration of conformity.



WARNING

Any use other than described is inappropriate.

1.4 Requirements on Operating and Service Personnel



WARNING

All persons employed in the operation, maintenance, installation, removal and disposal of the device must

- be at least 18 years old,
 - be mentally and physically suited for these activities,
 - be demonstrably trained and instructed in writing,
 - have read and understood the operating instructions, especially the instructions what to do in the event of defects or malfunctions,
 - be on record as having been instructed in safety guidelines,
 - have practical experience in working with vehicle lifts and the hazards inherent in such equipment.
-

1.5 Safety Instructions for Commissioning



WARNING

- The equipment shall be installed and commissioned by authorised service personnel only.
-

1.6 Safety Instructions for Operation



WARNING

- Observe the detailed operating instructions.
 - Comply with legal accident prevention regulations.
 - The permissible load capacity according to the rating plate must not be exceeded.
 - Before pressing the transmit button, check whether the channel of the radio hand lamp matches the receiver's channel. No equipment that might also respond to this channel may be located anywhere on the premises. The unin-
-

tended operation of other equipment may put people at risk.

Furthermore, no transmission equipment that could respond to the axle play detector may be located anywhere on the premises.

- To prevent injuries caused by impact or being run over, a sufficient safe distance from the vehicle to be tested must be maintained when it is being driven onto and off the test equipment.
 - Before testing, the vehicle to be tested must be secured against rolling away. When used on sloped surfaces (e.g. access ramps in mobile test lanes), it is advisable to have someone man the driver's cab during testing so they can respond to unintended movements.
 - Wear personal protective equipment.
 - A sufficient safety distance from the surface of the test plates' movement area must be maintained. Risk of crushing and shearing!
 - Test plates must not be walked on, even when not in use. There is a risk of falling due to unexpected test plate movements. There is a risk of slipping due to water or ice on the test plates.
 - During operation avoid lateral shifting of the vehicle on the test plates and continually monitor the position of both wheels on the test plates. Should the wheels move close to the edge of the test plates, stop the test immediately and reposition the vehicle.
 - Periodically check the fastening screws of the test plates for tight fit.
-

1.7 Safety Instructions for Servicing



WARNING

- Service work may be done by authorised service technicians only.
 - Turn off and padlock the main switch before doing any repair, maintenance or setup work.
 - Work on the electrical equipment may be done by service technicians or certified electricians only.
 - Ensure that ecologically harmful substances are disposed of only in accordance with the appropriate regulations.
-

1.8 Safety Instructions for Handling Hydraulic Fluid



CAUTION

- Neutralise hydraulic fluid spills with binder.
 - Remove contaminated clothing immediately.
 - Inhalation: If symptoms persist, seek medical treatment.
 - Skin contact: Wash skin immediately with soap and water. If skin irritation persists, seek immediate medical advice.
 - Eye contact: Rinse thoroughly with water and seek medical advice.
 - Ingestion: Do not induce vomiting. Seek immediate medical attention.
-

2 Transport and Storage

NOTICE

Check package to ensure it is complete, in accordance with the order confirmation. Report any transport damage to the carrier immediately.

During loading, unloading and transport always use suitable lifting equipment, material handling equipment (e.g. cranes, forklifts, etc.) and the right load handling attachments and slings. Always ensure that the parts to be transported are suspended or loaded properly so that they cannot fall, taking into account size, weight and the centre of gravity.

Store the packages in a covered area, protected from direct sunlight, at a low humidity and with temperatures between 0...+40 °C (32...104 °F). Do not stack packages.

When unpacking, take care to avoid any possibility of injury or damage. Keep at a safe distance when opening the package strapping, do not allow any parts to fall out.

3 Installation and Initial Operation



WARNING

Installation and initial operation of the equipment may be done only by authorized and trained service technicians provided by the manufacturer, licensed dealers or service partners.



WARNING

Before connecting the power supply, make sure that an external, lockable EMERGENCY-STOP MAIN SWITCH is used. This must be provided by the customer and installed in the power supply line to the control. The EMERGENCY-STOP MAIN SWITCH must meet the requirements of EN ISO 13850.

NOTICE

The fastening screws of the PMS must be slightly greased and tightened to a torque of 120 ± 5 Nm.

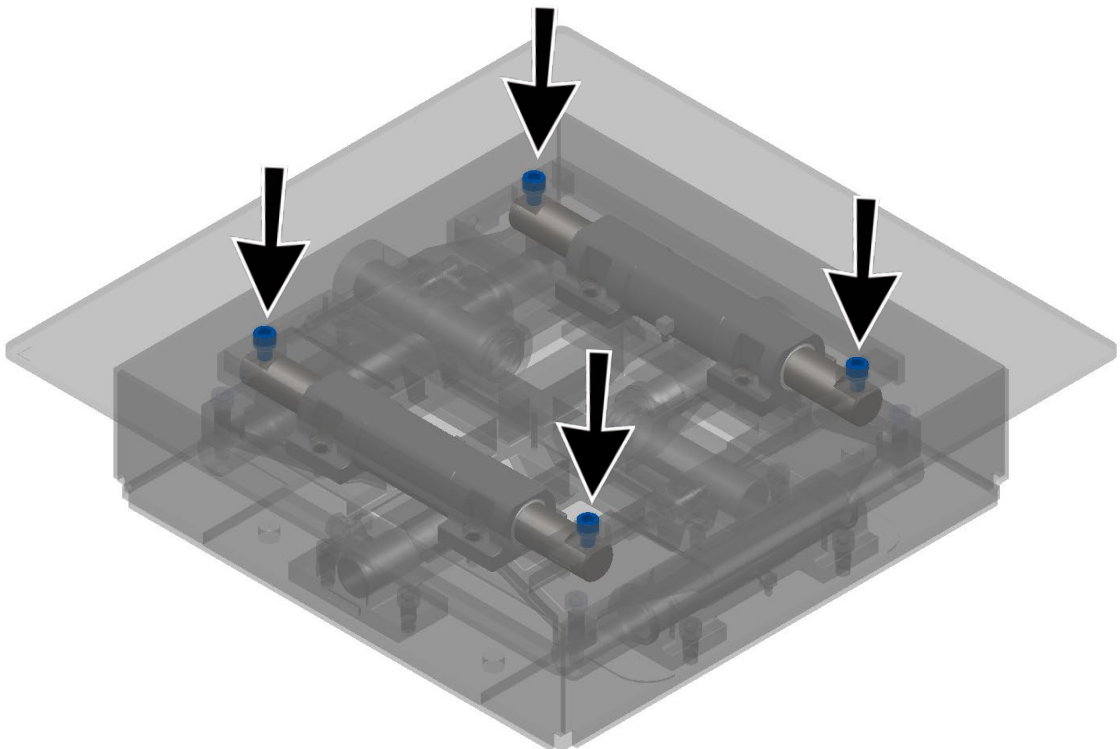

4 Operation

4.1 Main Switch

The main switch is also used as emergency switch.

Main switch in position 0

→ Lift is disconnected from power supply

Main switch in position 1

→ Lift is ready for operation



When in position 0, the main switch can be protected against tampering by means of a padlock.

4.2 Preparing for Operation

Examine the danger zone and ensure that warnings are legible. Damaged or illegible warnings and markings must be replaced immediately.

When operating an axle play detector in a mobile test lane, it must be ensured that all the hydraulic components' covers are fitted and do not show any signs of damage that would restrict functionality or signs of poor attachment.

If light conditions vary a great deal between test objects and peripherals (e.g. when used in mobile test lanes outdoors), sufficient lighting or glare protection must be provided.

A sufficiently ergonomic positioning option must be provided for performing the test (particularly for vehicle testing in mobile test lanes).



WARNING

- Test plates must not be walked on, even when not in use. There is a risk of falling due to unexpected test plate movements. There is a risk of slipping due to water or ice on the test plates.
 - During operation avoid lateral shifting of the vehicle on the test plates and continually monitor the position of both wheels on the test plates. Should the wheels move close to the edge of the test plates, stop the test immediately and reposition the vehicle.
-

4.3 Operating the Axle Play Detector



WARNING

- The hand lamp must be carried in such a way that eliminates the risk of unintentional operation of the axle play detector. For safety reasons, it is advisable to stay within the axle play detector's field of vision and danger zone when using the hand lamp.
-

NOTICE

- The hydraulic unit must never be left running for longer than absolutely necessary, as the pump can become damaged otherwise.
 - The hand lamp must be protected against shocks to ensure that the light bulb has a long service life.
-



- Some types of axle play detector are equipped with a synchronisation switch on the control box which enables control of the plates' lengthwise and/or crosswise movement.
 - If the plates are moved back and forth in the direction of travel, the brake must be applied as the turning wheels would otherwise follow the plates' movements.
 - Attempts should always be made to cause the vehicle wheel to slip onto the plates, as this is the best way to detect incorrect axle play.
-

- 1 Switch the test device on at the main switch.
- 2 Drive the vehicle to be tested onto the test plates at walking speed and secure it against rolling away, e.g. apply the parking brake or use chocks.
- 3 The testing plates can be operated using the hand lamp's push-button functions.
- 4 Switch the light and the hydraulic unit off after testing.
- 5 Drive the vehicle off the test plates.
- 6 Place the hand lamp in the charging holder to charge.

4.4 Operating the Cable Hand Lamp

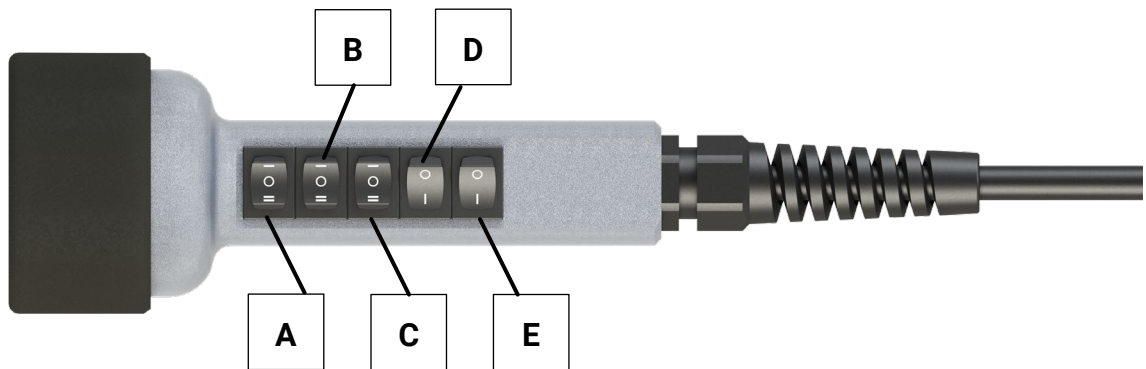

A / B Movement of test plates

C / E Selection of movement (such as switch-over between single, synchronous, counter or diagonal movement)

D Switch on and off the lamp

4.4.1 LMS 20.0 TL A (Above-Floor) with Cable Hand Lamp

NOTICE

In the case of imminent water ingress (due to rain, cleaning process, etc.), unplug the cable hand lamp from the socket on the power unit casing, and keep it protected from water. Close the socket.



4.5 Operating the Radio Hand Lamp RHL (Option)



See separate Operating Instructions.

4.6 Service Mode

To remove the sliding plates, the hydraulic cylinders must be pressure relieved. To do this, a Service mode was integrated. When this mode is enabled, only the valves are driven as in the normal operating mode. The hydraulic pump remains OFF.

Enable Service Mode

- Cable hand lamp: Push and hold rocker buttons A and B together for 10 seconds. The pump switches off. (Simultaneous actuation of A1 and B1 or A2 and B2).
Once the second button is detected, the valves are switched off. The pump remains ON until 10 seconds have elapsed. The plates remain in their last position.
- Radio hand lamp: Set to mode LED ON (Manual operating button). To enable the Service mode, push and hold the operating button for 25 seconds. During this time period, the valve is ON and the pump is also ON. After 25 seconds the pump switches OFF. The valve remains ON.

Function while Service Mode is Enabled

When in the Service mode, the valves of the corresponding moving directions can be driven using the operating buttons, and the plates can be moved by hand.

On the MAH CAN RP circuit board the Service mode is indicated by the yellow LED of VD20.

Quit Service Mode

- Cable hand lamp: Push and hold rocker buttons A and B together for 10 seconds. The output for the pump switches ON and the Service mode is quit.
- Radio hand lamp: Set to mode LED ON. Push and hold the operating button for 25 seconds to quit the Service mode. After 25 seconds the pump switches ON.

Alternatively, the Service mode can be quit by switching off the power supply.

4.7 Operating Diagrams



See Annex.

5 Maintenance



DANGER

Risk of death or severe personal injury by electric shock



Before doing any maintenance work, turn off the main switch and protect it against tampering.

5.1 Maintenance Schedule

Interval	Maintenance Items	Procedure
3 months	Hydraulic system	Check fluid level, refill if necessary.
		Check hydraulic system for leakages.
		Check power unit for unusual noise during operation, check fastening screws for tight fit.
6 months	Hydraulic fluid	Check fluid for contamination and aging, replace if necessary.
12 months	General inspection	Check all components for damage.
6 years	Pressure hoses	Replace pressure hoses

5.2 Annual Inspection



- The maintenance interval prescribed by the manufacturer is 12 (twelve) months. This maintenance interval refers to normal workshop usage. If the equipment is used more frequently or under severe operating conditions (e.g. outdoors), the interval must be reduced accordingly.
 - Maintenance work shall be done only by authorised and trained service technicians provided by the manufacturer, licensed dealers or service partners.
 - In case of non-compliance the manufacturer's warranty becomes void.
-

5.3 Maintenance by the Operator

NOTICE

Relieve the pressure to remove the test plates; activate service mode for this purpose (see section "Operation > Service Mode").

- Remove the test plates and lubricate the guides with a grease gun or grease the plastic sliding strips every 200 operating hours, but at least every three months. In the case of PMS plates installed in lift runways, lubrication can take place directly from below.
- Check that all the guide rods are secure and tighten them if necessary.
- Check the oil level regularly and top it up if necessary. The oil level must be between the two marks.
- Change the hydraulic oil every two years. Please see the section entitled "Specifications" for the filling quantity and specifications.

5.4 Greasing Points

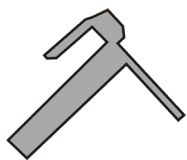

Lubricating with
a grease gun



Greasing with a brush

PMS plates in lift runways (view: underside of the runways)

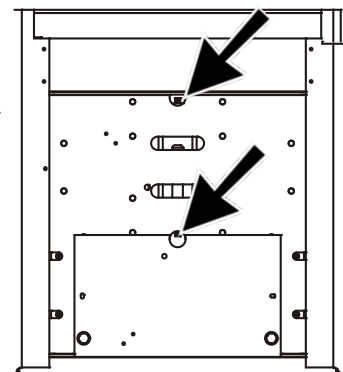
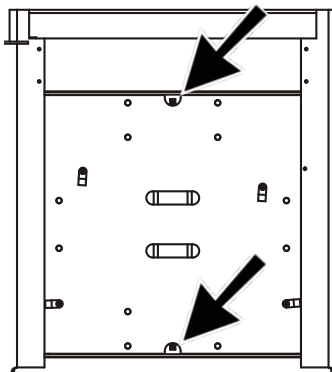

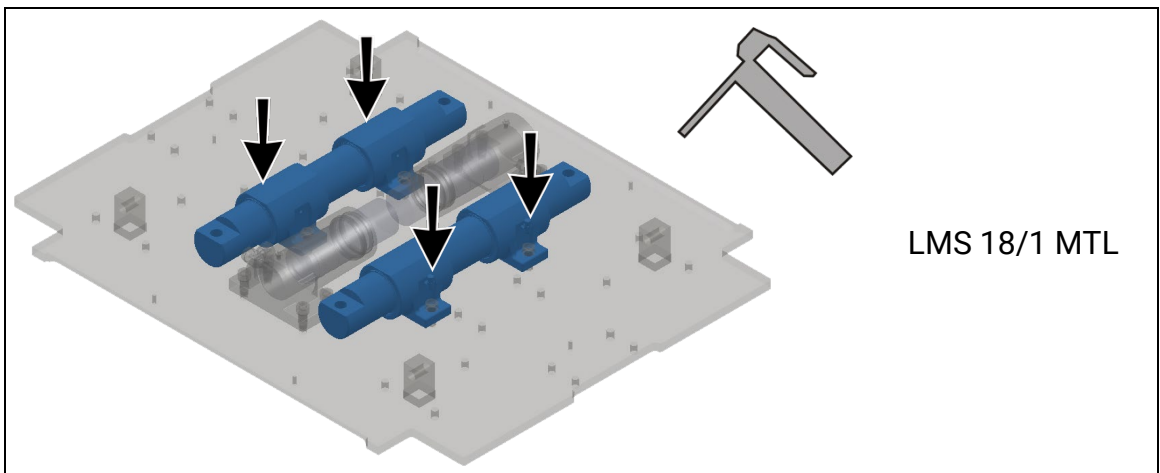
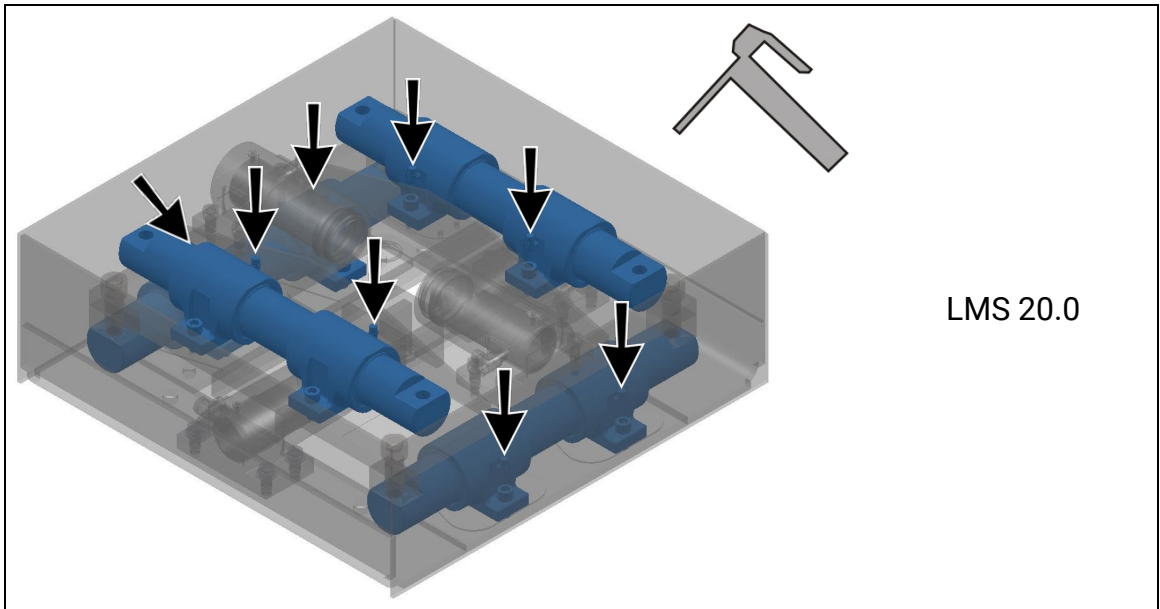
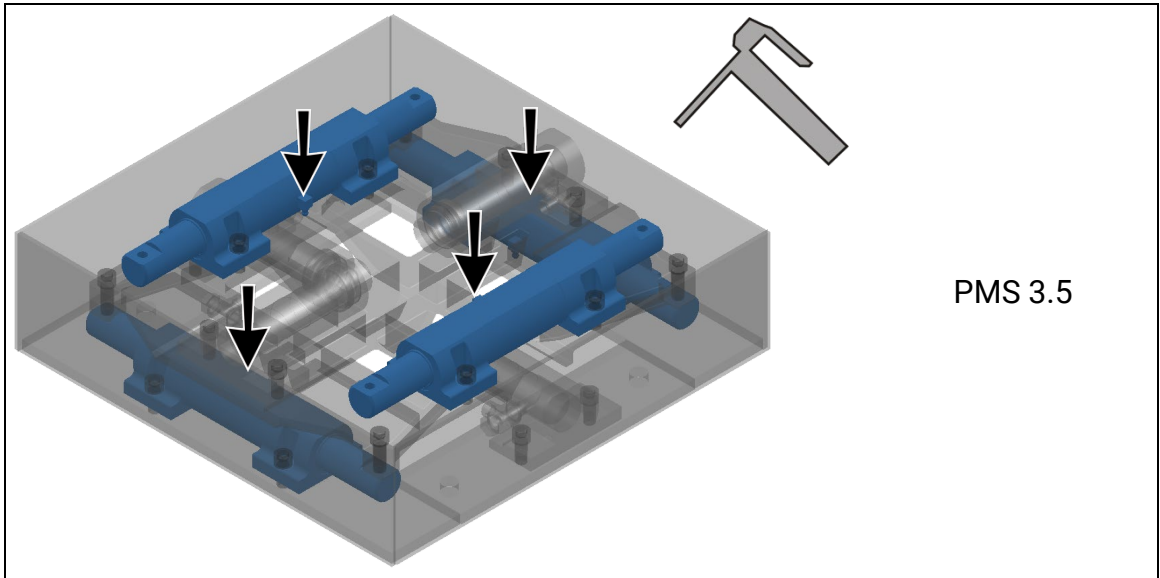

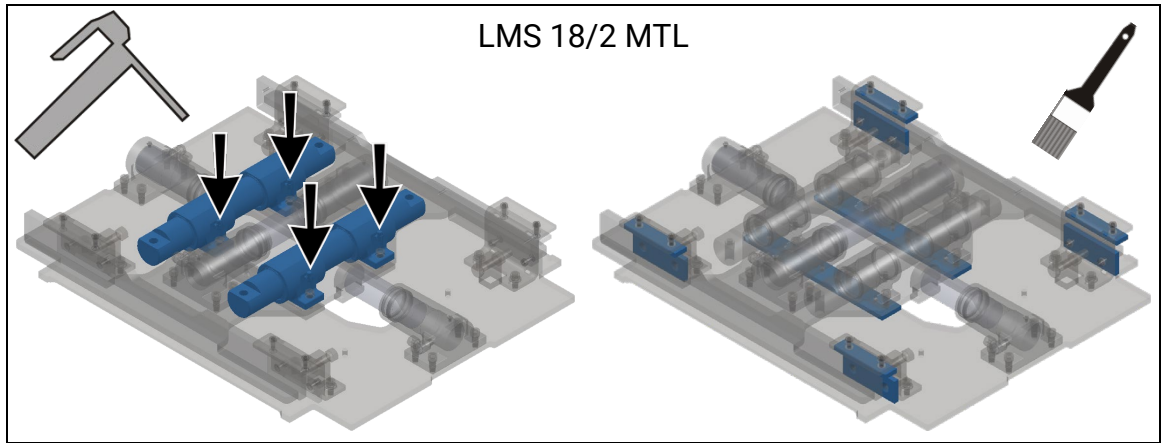

5.5 Care Instructions

NOTICE

Regular care and maintenance is the key condition for functionality and long life expectancy of the equipment.

- Periodically clean the equipment and treat it with a care product.
- Repair damage to the paintwork immediately to prevent corrosion.
- Do not use caustic cleaning agents or high pressure and steam jet cleaners to avoid equipment damage.

5.6 Spare Parts

To ensure safe and reliable operation, only use original spare parts supplied by the equipment manufacturer.

5.7 PMS Variants for Installation on Lift Runways

PMS 3/R

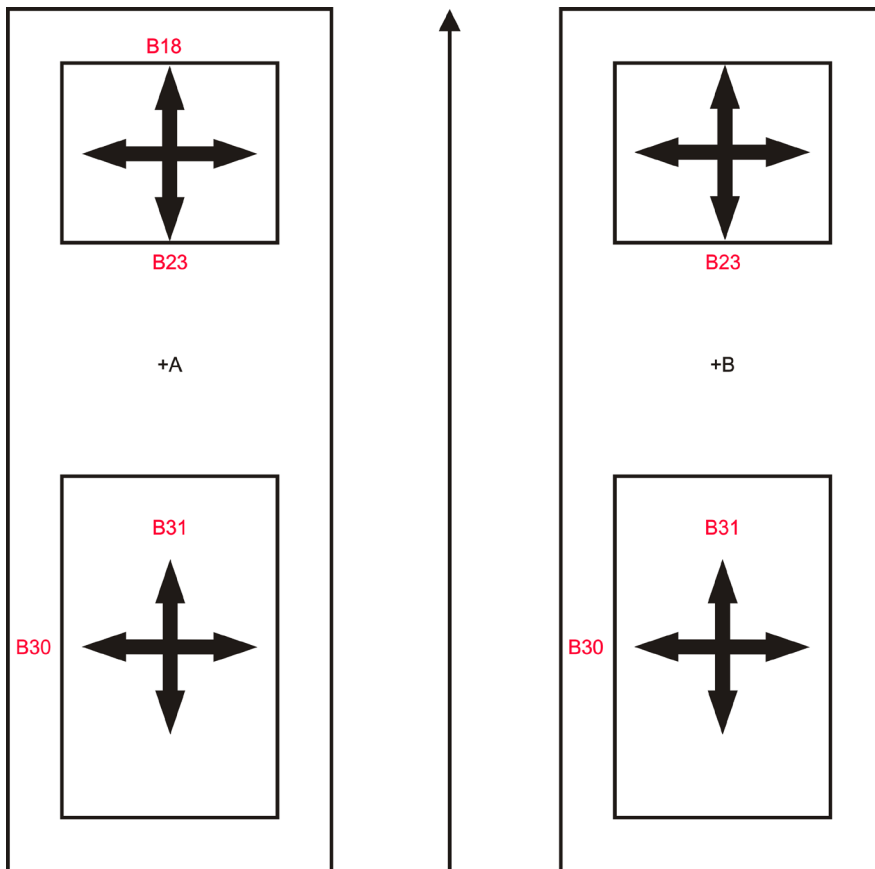

PMS 3X or PMS 3XL

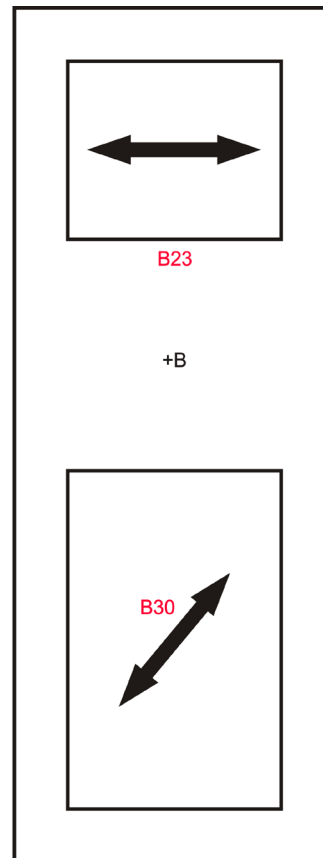
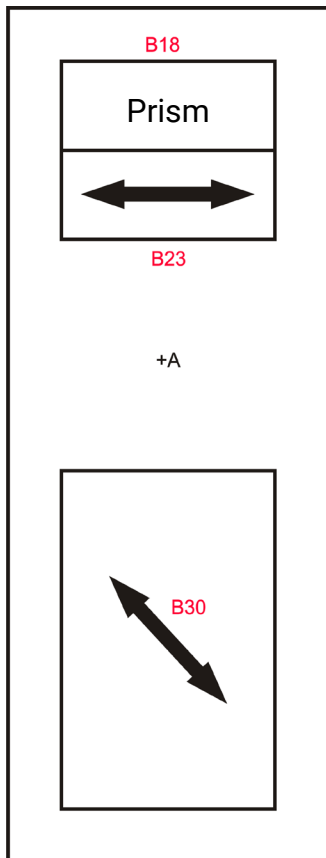

PMS 3X
Available with a
pneumatic
prism as an
option =
PMS 3XL

Optional:
PMS 3D

B18, B23, B30, B31 for centring in the 10 t option.



The front axle is centred first of all, followed by the rear axle.

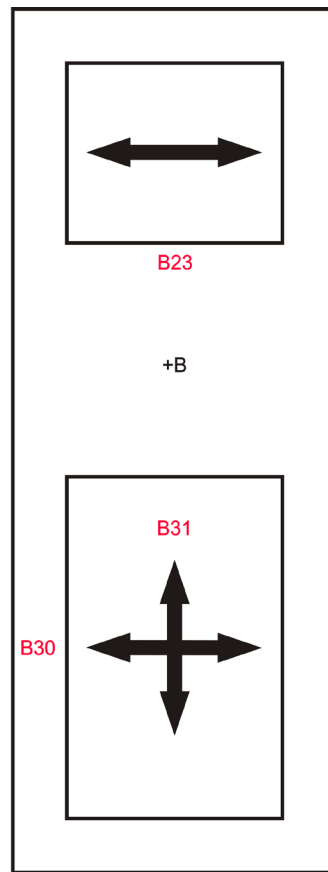
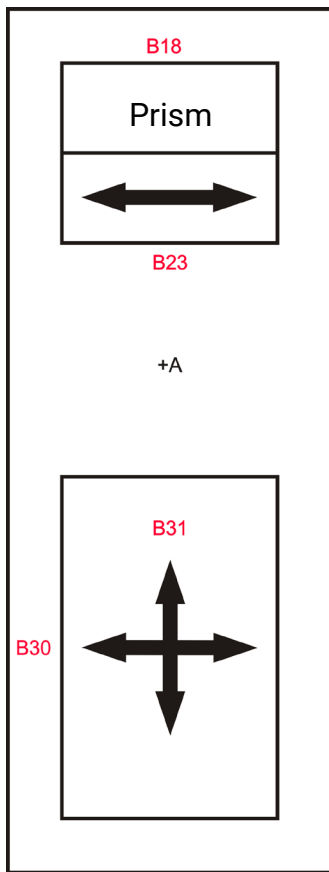

PMS 3X
Available with a
pneumatic
prism as an
option=
PMS 3XL

Optional:
PMS 3R

PMS 3P (Pneumatic)

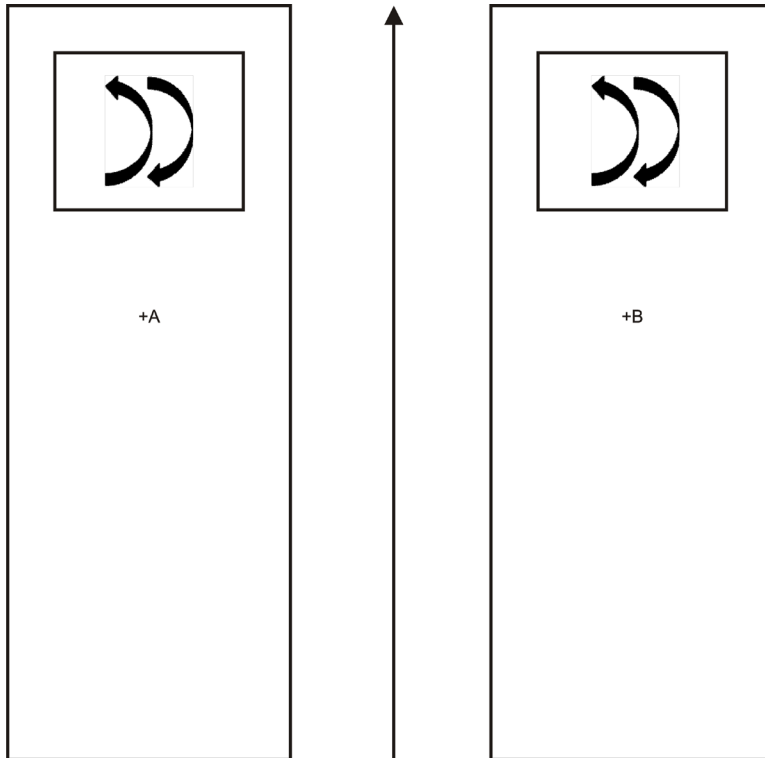

PMS 3P
Standard:
test plate on the
left and right
ATL:
one plate on the
right in the
direction of
travel only

PMS 3XIE

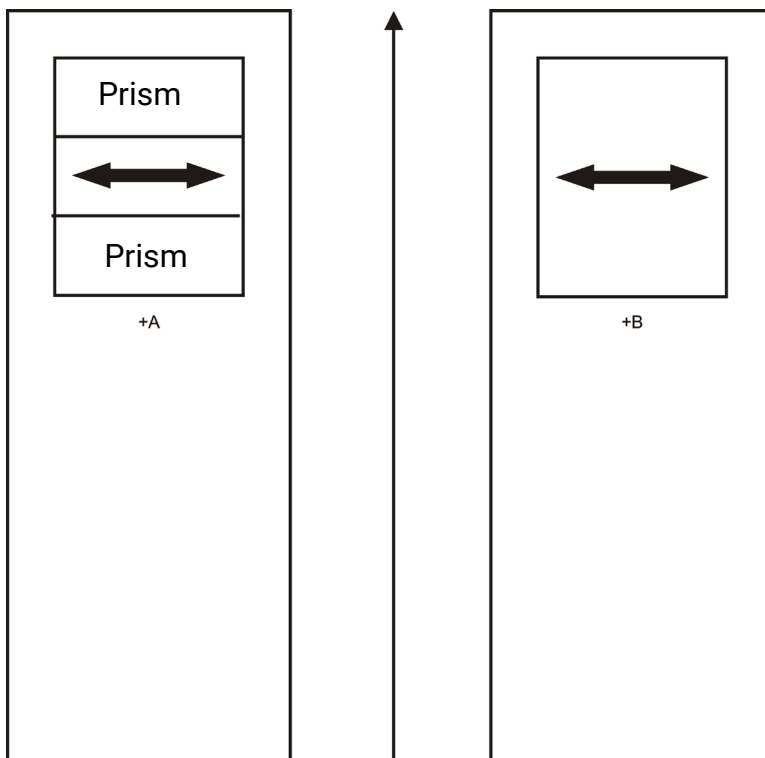

PMS 3XIE
With two
pneumatic
prisms

6 Specifications

6.1 PMS Specifications

	PMS 3.5 PMS 3/D PIT	PMS 3.5 Double	PMS 3/P PIT	PMS 3/X	PMS 3/XL
Axle load max.	3500 kg	3500 kg	2800 kg	3500 kg	3500 kg
Wheel load max.	1750 kg	1750 kg	1400 kg	1750 kg	1750 kg
TP Dimensions	625x625 mm	625x625 mm (FA) 1310x625 mm (RA)	426x560 mm	248x550 mm (left, 2x) 500x550 mm (right)	248x550 mm (left, ApS) 155x460 mm (left, ExS) 500x550 mm (right)
Installation height incl. TP	148 mm	148 mm	185 mm	127.5 mm (left) 92.5 mm (right)	127.5 mm (left) 92.5 mm (right)
TP height above floor	15 mm	15 mm	10 mm	---	---
Thrust per side max.	11 kN	11 kN	10 kN	11 kN	11 kN
Movement per side max.	100 mm	100 mm	24°	77 mm	77 mm
TP speed (2 TP simultaneously)	75 mm	75 mm	---	adjustable	adjustable
Hydraulic pressure max.	120 bar	120 bar	---	120 bar	120 bar
Pneumatic pressure max.	---	---	10 bar	---	---
Hydraulic fluid	HLPD 32	HLPD 32	---	see Lift	see Lift
Filling quantity of hydraulic unit	8.5 L	8.5 L	---	see Lift	see Lift
Supply voltage	3x400 V	3x400 V	---	see Lift	see Lift
Rated motor power	2.5 kW	2.5 kW	---	see Lift	see Lift
Fuse	16 A slow	16 A slow	---	see Lift	see Lift
Control voltage of cable hand lamp	24 V	24 V	---	24 V	24 V

Abbr.: TP = Test Plate(s); FA = Front Axle; RA = Rear Axle;
ApS = Approach Side; ExS = Exit Side

6.2 LMS Specifications

	LMS 20.0	LMS 20.0 flush-floor	LMS 20.0 extended TP	LMS 18/1 MTL LMS 18/2 MTL
Axle load max.	20 000 kg	20 000 kg	20 000 kg	18 000 kg
Wheel load max.	10 000 kg	10 000 kg	10 000 kg	9000 kg
TP Dimensions	740x740 mm	740x740 mm	1310x740 mm	712x712 mm
Installation height incl. TP	232 mm	232 mm	232 mm	170 mm
TP height above floor	15 mm	0 mm	15 mm	20 mm
Thrust per side max.	30 kN	30 kN	30 kN	30 kN
Movement per side max.	100 mm	100 mm	100 mm	100 mm
TP speed (2 TP simultaneously)	60 mm/s	60 mm/s	60 mm/s	30 mm/s
Hydraulic pressure max.	120 bar	120 bar	120 bar	120 bar
Hydraulic fluid	HLPD 32	HLPD 32	HLPD 32	HLPD 32
Filling quantity of hydraulic unit	20.3 L	20.3 L	20.3 L	8.5 L
Supply voltage	3x400 V	3x400 V	3x400 V	3x400 V
Rated motor power	2.5 kW	2.5 kW	2.5 kW	2.5 kW
Fuse	16 A slow	16 A slow	16 A slow	16 A slow
Control voltage of cable hand lamp	24 V	24 V	24 V	---

Abbr.: TP = Test Plate(s)

7 Dismantling

Decommissioning and dismantling of the equipment may be done only by specially authorized and trained personnel provided by the manufacturer, licensed dealers or service partners.

8 Disposal

Pay attention to the product and safety data sheets of the lubricant used. Avoid damage to the environment. Should a disposal of the device be necessary it must be done in adherence with locally applicable legal regulations regarding environmental protection. Remove all materials properly sorted out and bring them to a suitable waste disposal service. Collect operating materials such as grease, oils, coolant, solvent-based cleaning fluids etc. in suitable containers and dispose of in an environmentally protective manner.

Alternatively, you may take the equipment to a specialised waste management plant to ensure that all components and operating liquids are properly disposed of.

9 Contents of the Declaration of Conformity

MAHA Maschinenbau Haldenwang GmbH & Co. KG

herewith declares as a manufacturer its sole responsibility to ensure that the product named hereafter meets the safety and health regulations both in design and construction required by the EC directives stated below.

This declaration becomes void if any change is made to the product that was not discussed and approved by named company beforehand.

Type:	PMS / LMS
Name:	Axle clearance tester for cars and trucks; permissible axle load 3,500 / 20,000 kg
Directives:	2006/42/EC; 2014/30/EU
Standards:	EN 12100-1/-2; EN 13850, EN 13857, EN 349; EN 60204-1; EN 61000-6-3, EN 61000-6-2

10 Annex: Operating Diagrams

See following page(s).

Funkhandlampe

radio hand lamp

linke Platte / rechte Platte
left plate / right plate

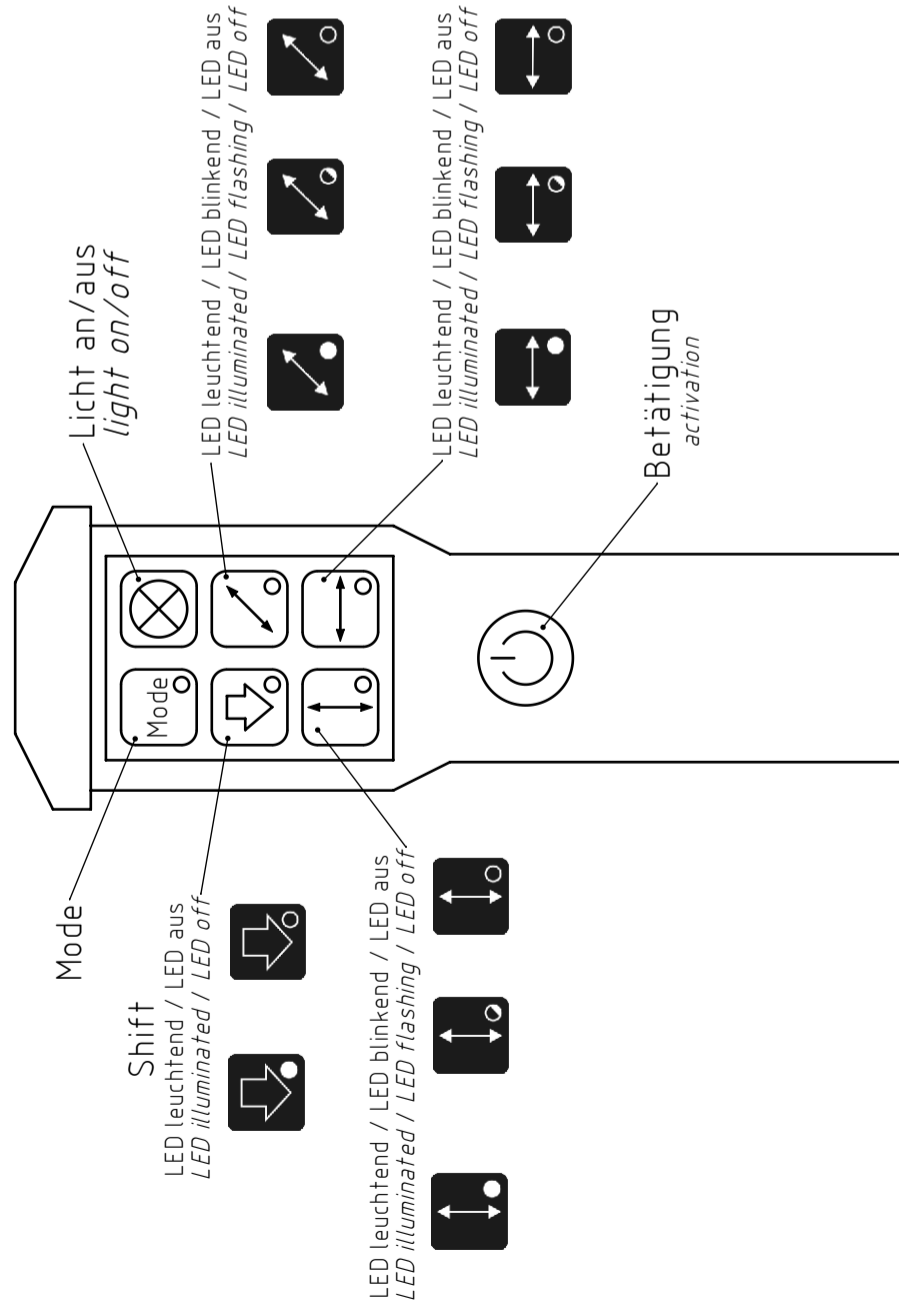
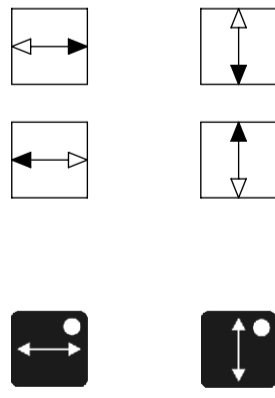

Kabelhandlampe

cable hand lamp

linke Platte / rechte Platte
left plate / right plate

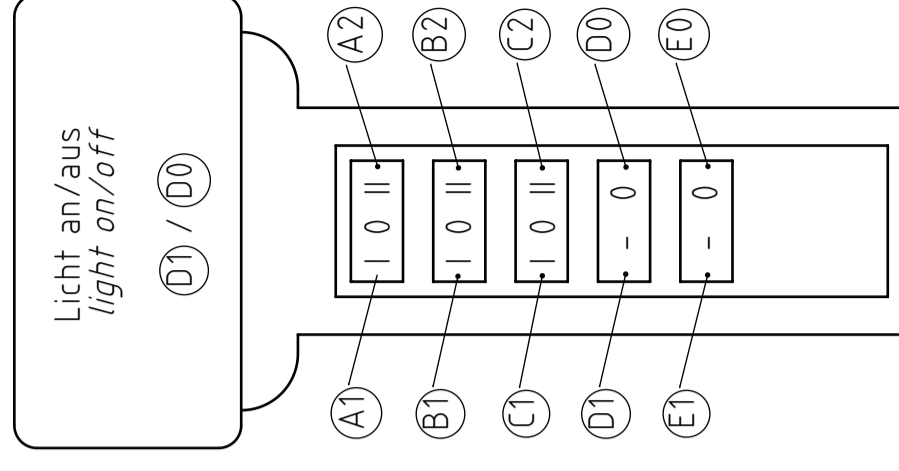
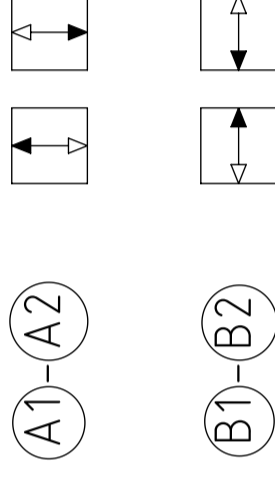

[1/8] PMS 3.5 & LMS 20.0 & LMS 18/2 MTL

Size ISO 14405 (E)	Schutzvermerk beachten nach DIN ISO 16016		Oberfläche		Werkstoff	
Allgemeintoleranzen	DIN ISO 2768-mK		Mindeststreckgrenze Re in N/mm ²		Werkstoffnummer	
	Maßstab	Nettogewicht in kg	Dokumenttyp		Änderungsnr.	Büro
	1:1	0.000	Fluid-Plan		100075	300
Benennung						
Fernbedienung PMS/LMS Bedienschema						
Materialnummer		Revision		Dokumentnummer		Version
3000007		00		10001022		Blatt 1 von 10
Datum, Ersteller		Datum, Prüfer		alte Materialnummer		A3
3.6.2019 MOBERMAY		02.09.2019 MOBERMAY		02.09.2019 MOBERMAY		

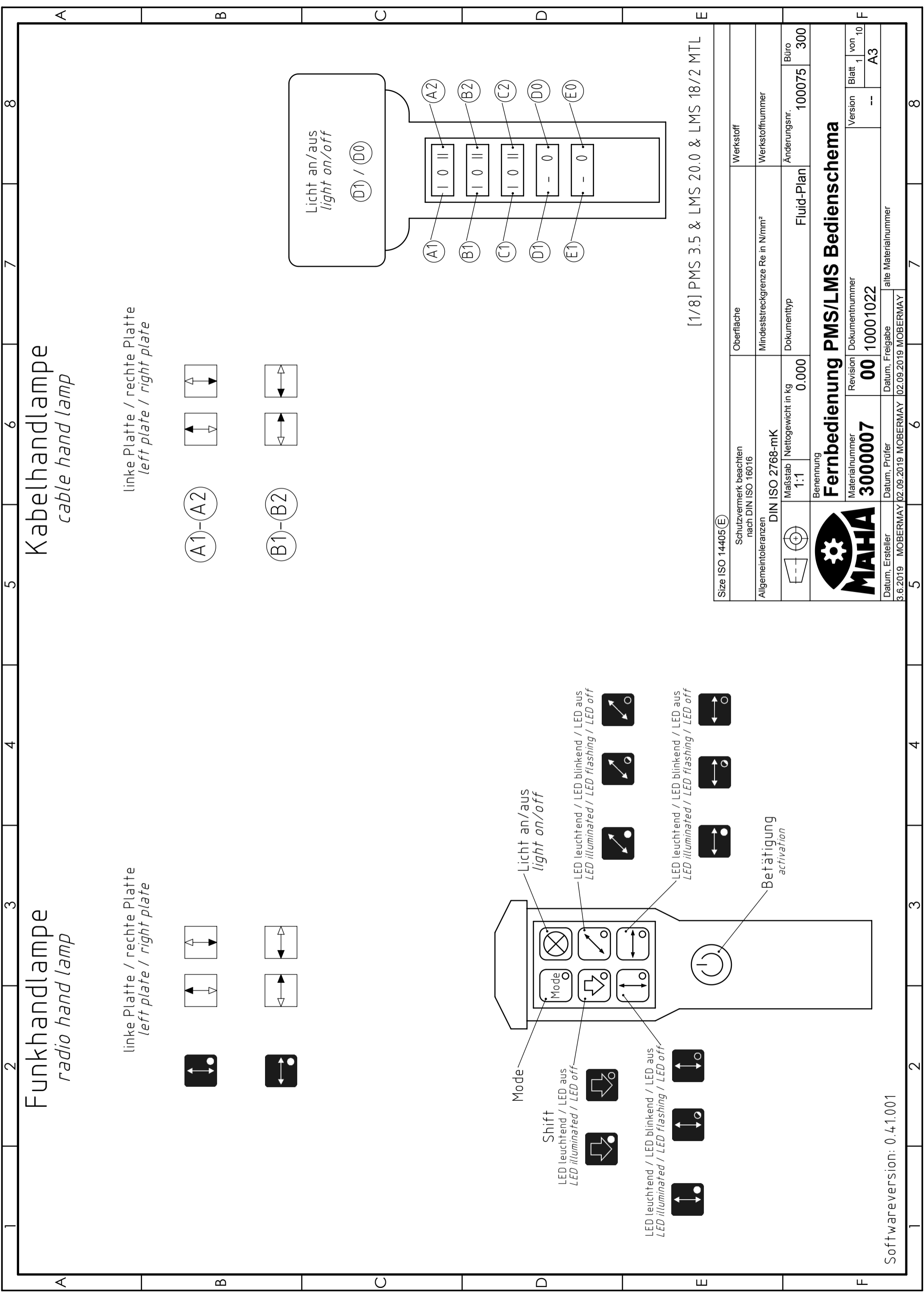

Funkhandlampe

radio hand lamp

linke Platte / rechte Platte
left plate / right plate

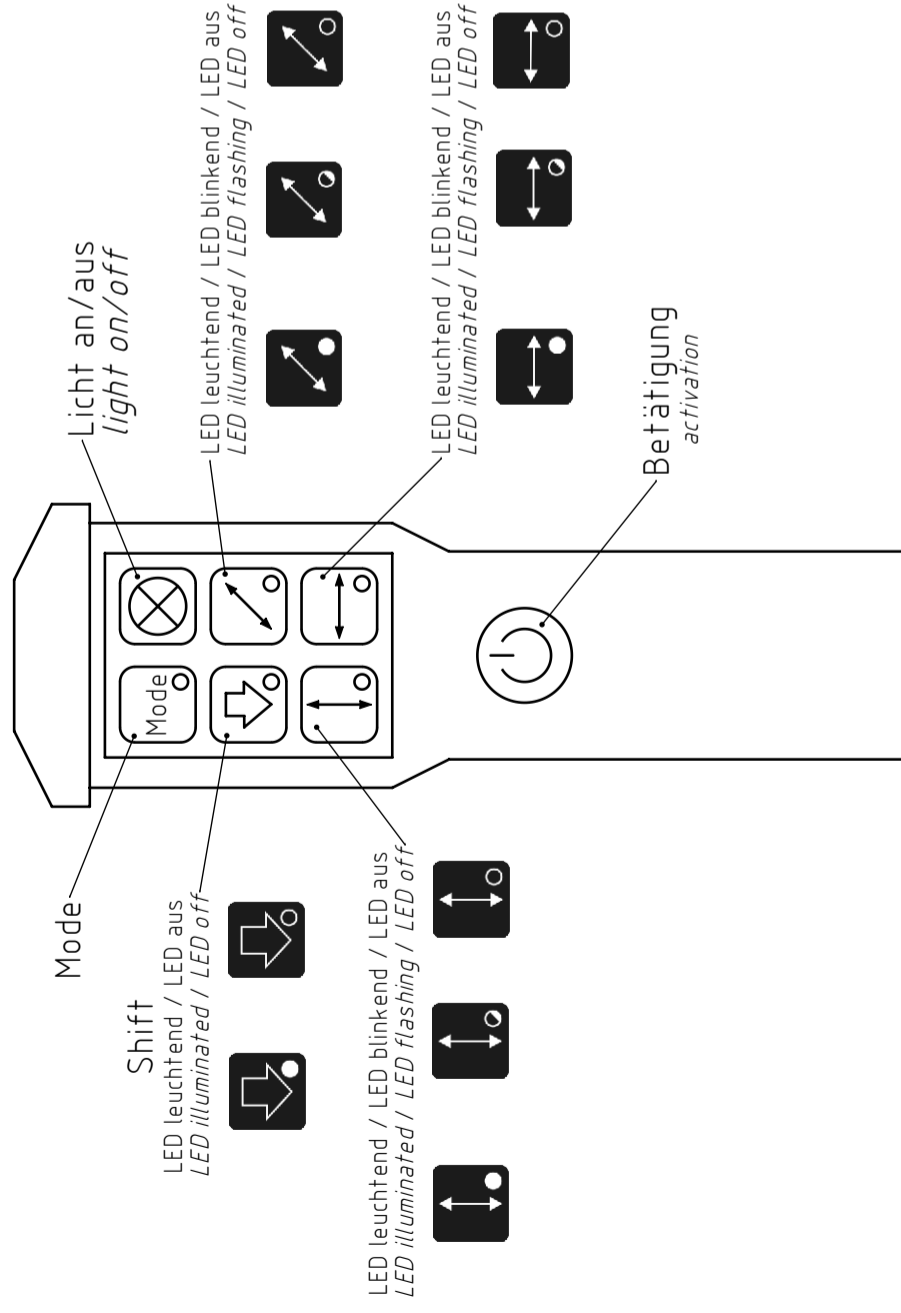
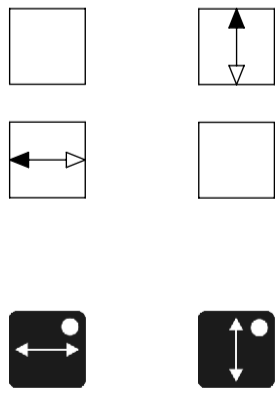

Kabelhandlampe

cable hand lamp

linke Platte / rechte Platte
left plate / right plate

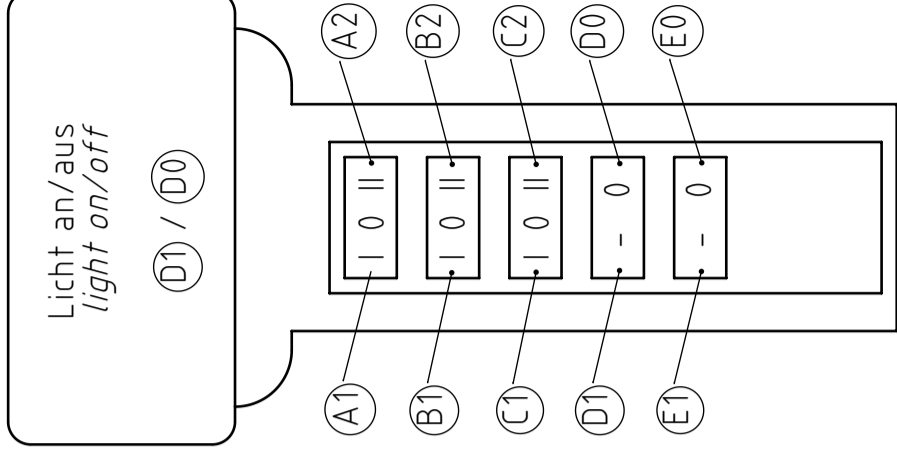
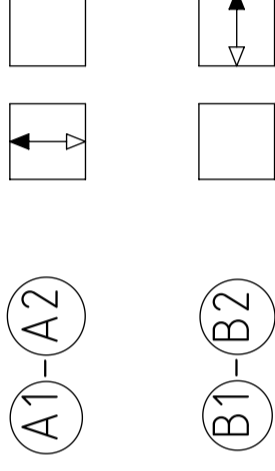

[2] LMS 20.0 ZA & LMS 18/1 MTL

Size ISO 14405 (E)	Schutzvermerk beachten nach DIN ISO 16016		Oberfläche	Werkstoff
Allgemeintoleranzen	DIN ISO 2768-mK		Mindeststreckgrenze Re in N/mm ²	Werkstoffnummer
	Maßstab	Nettogewicht in kg	Dokumenttyp	Änderungsnr.
	1:1	0.000	Fluid-Plan	100075
		Büro 300		
Benennung				
Fernbedienung PMS/LMS Bedienschema				
Materialnummer	Revision	Dokumentnummer	Version	Blatt von
3000007	00	10001022	--	10
Datum, Prüfer	Datum, Freigabe	alte Materialnummer		
02.09.2019 MOBERMAY	02.09.2019 MOBERMAY			

Funkhandlampe

radio hand lamp

linke Platte / rechte Platte
left plate / right plate

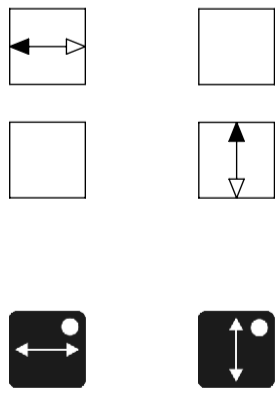

Kabelhandlampe

cable hand lamp

linke Platte / rechte Platte
left plate / right plate

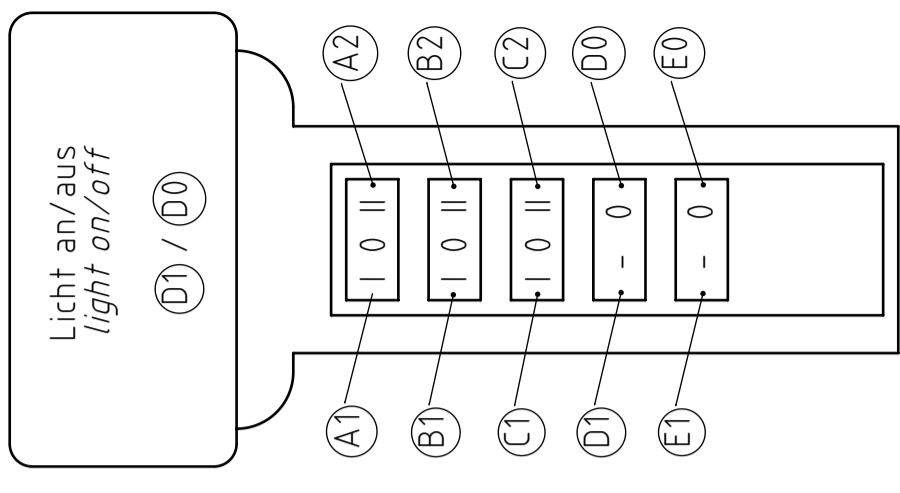
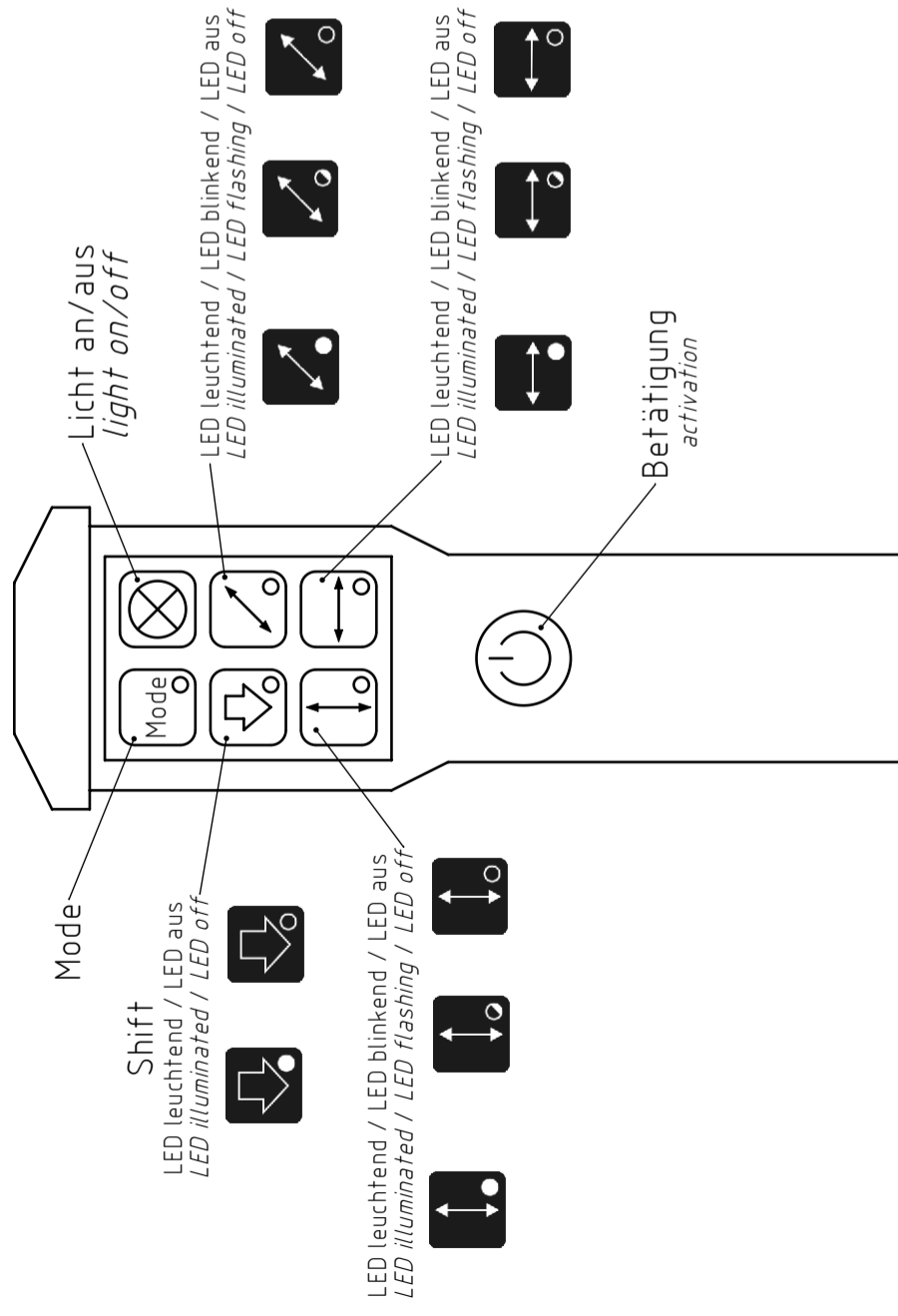
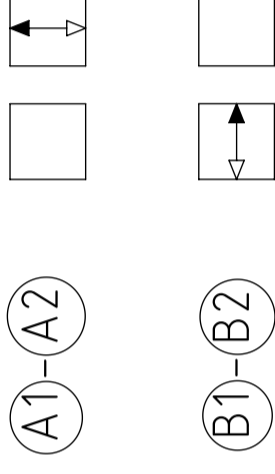

[1] LMS 20.0 NZ

Size ISO 14405 (E)	Schutzvermerk beachten nach DIN ISO 16016		Oberfläche	Werkstoff
Allgemeintoleranzen	DIN ISO 2768-mK		Mindeststreckgrenze Re in N/mm ²	Werkstoffnummer
	Maßstab 1:1	Nettogewicht in kg 0.000	Dokumenttyp Fluid-Plan	Änderungsnr. 100075
Benennung		Büro 300		
Fernbedienung PMS/LMS Bedienschema				
Materialnummer 3000007		Revision 00	Dokumentnummer 10001022	Version 3
Datum, Ersteller 02.09.2019 MOBERMAY		Datum, Prüfer 02.09.2019 MOBERMAY	alte Materialnummer A3	

Funkhandlampe radio hand lamp

linke Platte / rechte Platte
left plate / right plate

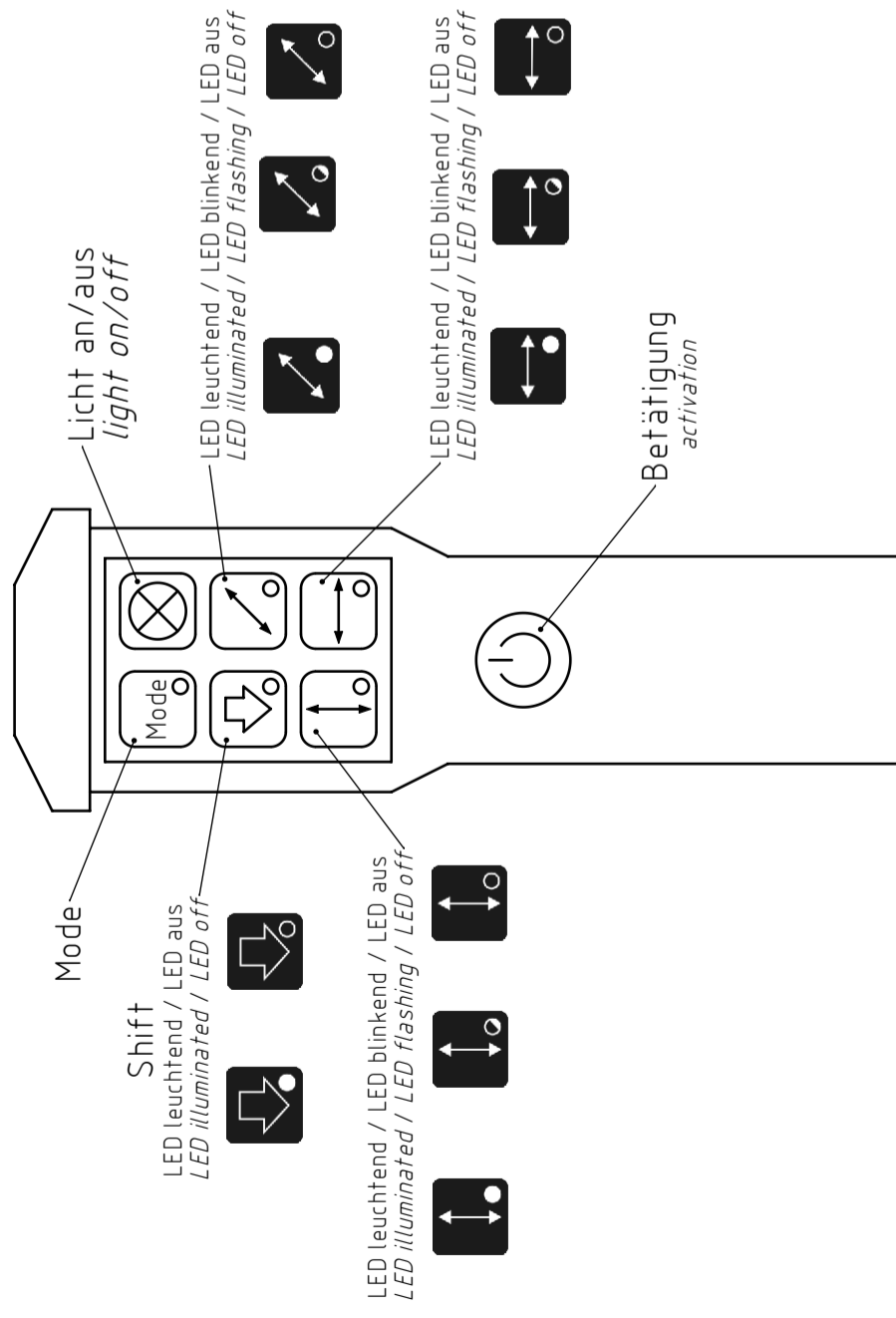
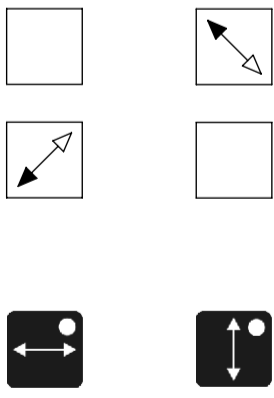

Kabelhandlampe cable hand lamp

linke Platte / rechte Platte
left plate / right plate

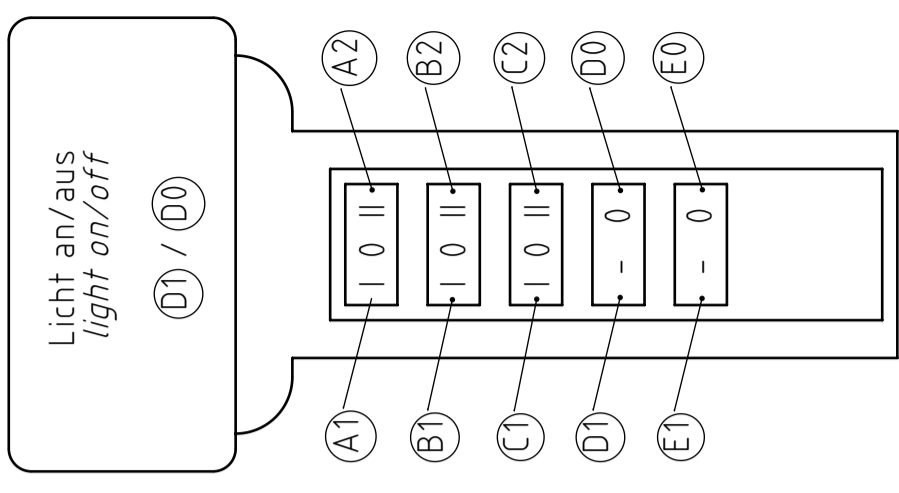
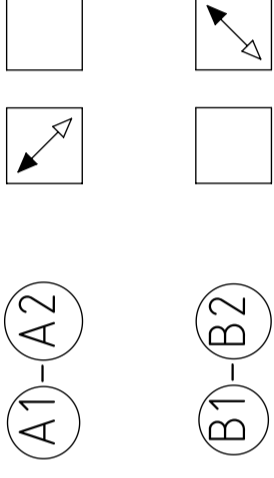

[1] PMS 3/D PIT

Size ISO 14405 (E)	Schutzvermerk beachten nach DIN ISO 16016		Oberfläche	Werkstoff
Allgemeintoleranzen	DIN ISO 2768-mK		Mindeststreckgrenze Re in N/mm ²	Werkstoffnummer
	Maßstab	Nettogewicht in kg	Dokumenttyp	Änderungsnr.
	1:1	0.000	Fluid-Plan	100075
			Büro	300
Benennung Fernbedienung PMS/LMS Bedienschema				
	Materialnummer	Revision	Dokumentnummer	Version
	3000007	00	10001022	Blatt 4 von 10 -- A3
Datum, Ersteller	Datum, Prüfer	alte Materialnummer		
3.6.2019 MOBERMAY	02.09.2019 MOBERMAY	02.09.2019 MOBERMAY		

Funkhandlampe

radio hand lamp

linke Platte / rechte Platte
left plate / right plate

linke Platte / rechte Platte
left plate / right plate

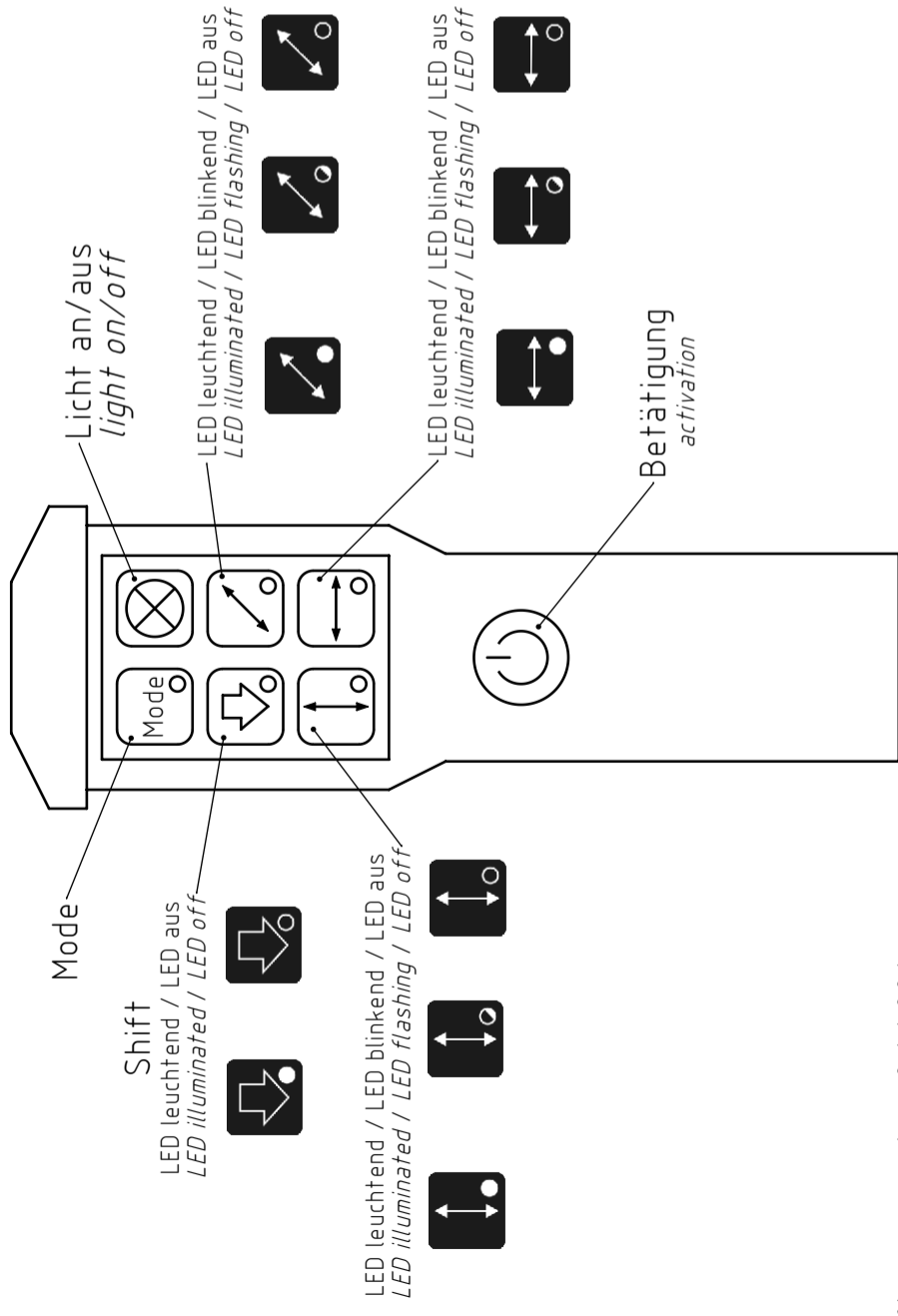
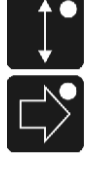
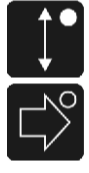
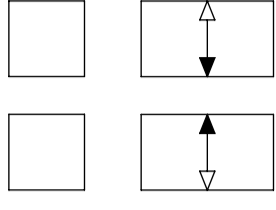
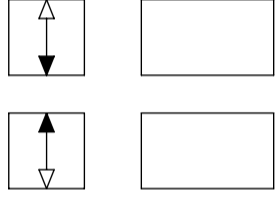
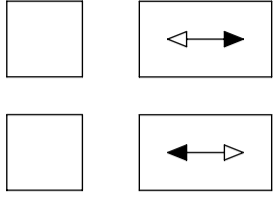
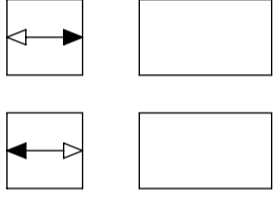

[2] PMS 3.5 Double (Funk)

Size ISO 14405 (E)		Oberfläche		Werkstoff	
Schutzvermerk beachten nach DIN ISO 16016					
Allgemeintoleranzen DIN ISO 2768-mK		Mindeststreckgrenze Re in N/mm ²		Werkstoffnummer	
Maßstab / Nettogewicht in kg 1:1 / 0.000		Dokumenttyp Fluid-Plan		Änderungsnr. 100075	
Benennung Fernbedienung PMS/LMS Bedienschema		Büro 300			
Materialnummer 3000007		Revisionsnummer 00		Version 5	
Datum, Prüfer 02.09.2019 MOBERMAY		alte Materialnummer 10001022		Blatt 10	
Datum, Ersteller 02.09.2019 MOBERMAY		alte Materialnummer 10001022		Blatt 5	
MOBERMAY		MOBERMAY		A3	

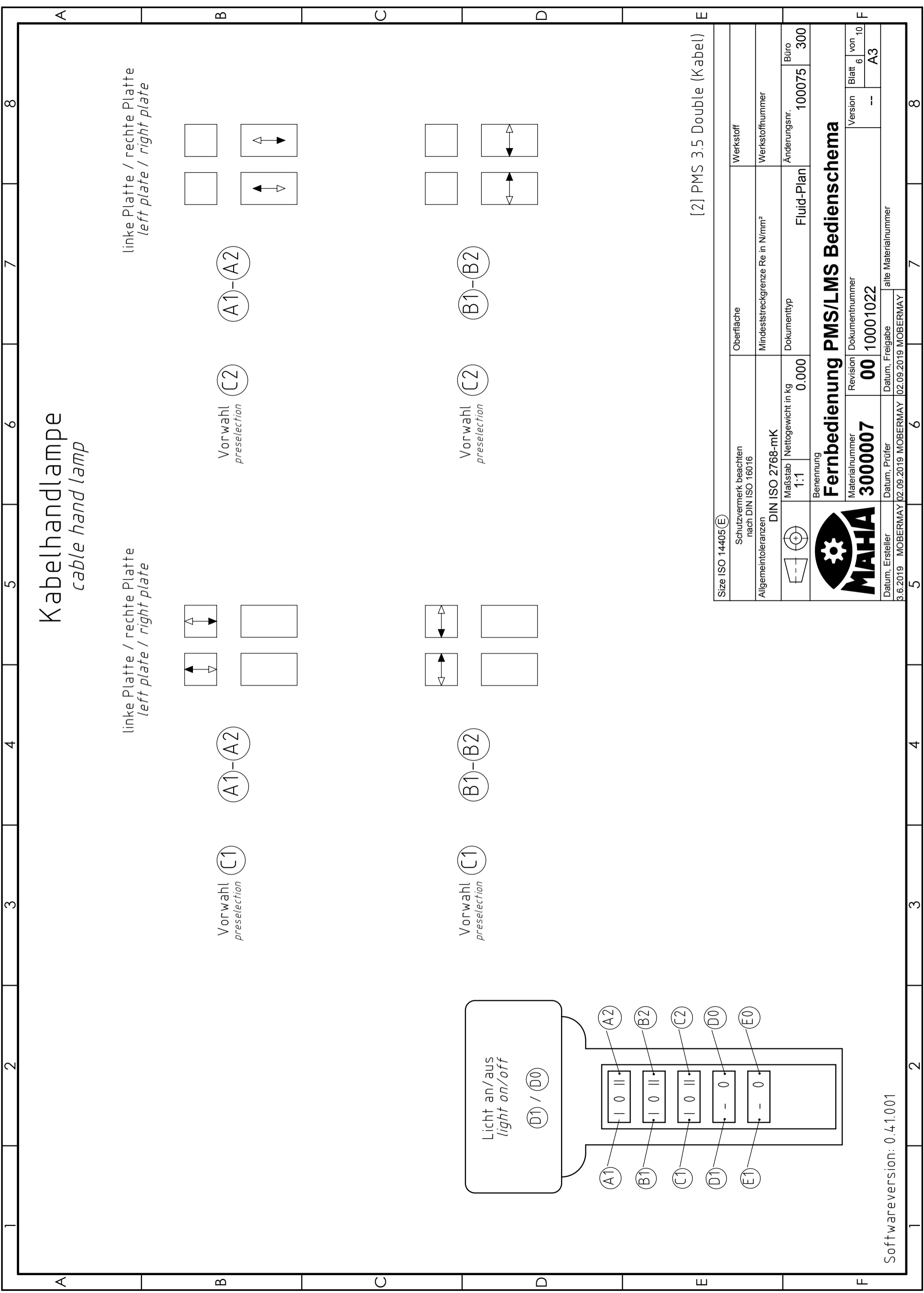

Kabelhandlampe

cable hand lamp

linke Platte / rechte Platte
left plate / right plate

linke Platte / rechte Platte
left plate / right plate

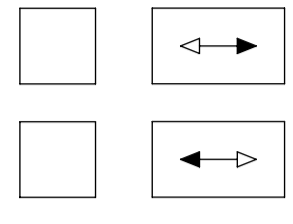
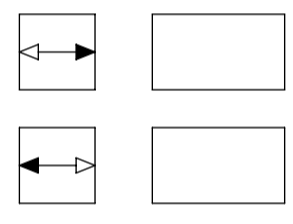

Vorwahl
preselection

Vorwahl
preselection

A1-A2

A1-A2

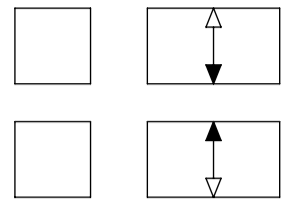
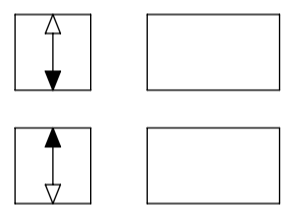

Vorwahl
preselection

Vorwahl
preselection

B1-B2

B1-B2

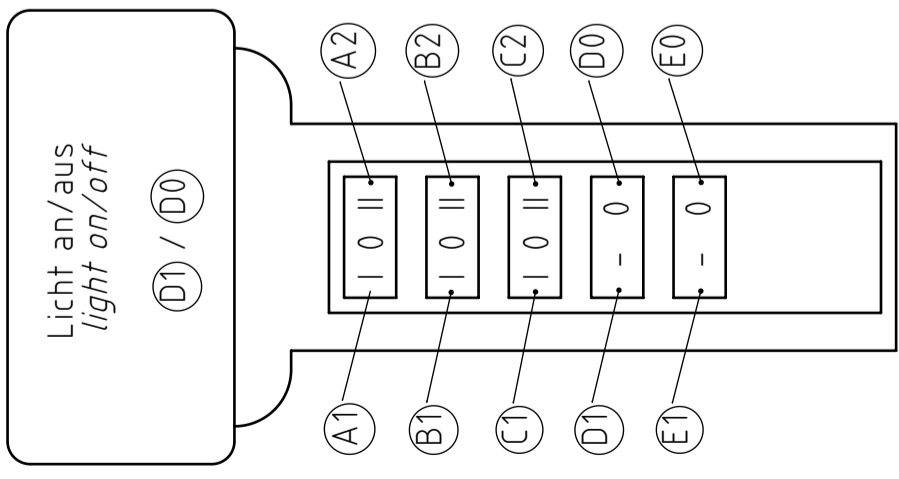

[2] PMS 3.5 Double (Kabel)

Size ISO 14405 (E)		Oberfläche		Werkstoff	
Schutzvermerk beachten nach DIN ISO 16016		Mindeststreckgrenze Re in N/mm ²		Werkstoffnummer	
Allgemeintoleranzen		Dokumenttyp		Änderungsnr.	
DIN ISO 2768-mK		Fluid-Plan		100075	
Maßstab 1:1		Nettogewicht in kg		Büro	
0.000		0.000		300	
Benennung		Fernbedienung PMS/LMS Bedienschema			
Materialnummer		Revision		Version	
3000007		00		6 10	
Datum, Ersteller		Datum, Freigabe		alte Materialnummer	
3.6.2019 MOBERMAY		02.09.2019 MOBERMAY		-- A3	

Funkhandlampe

radio hand lamp

linke Platte / rechte Platte
left plate / right plate

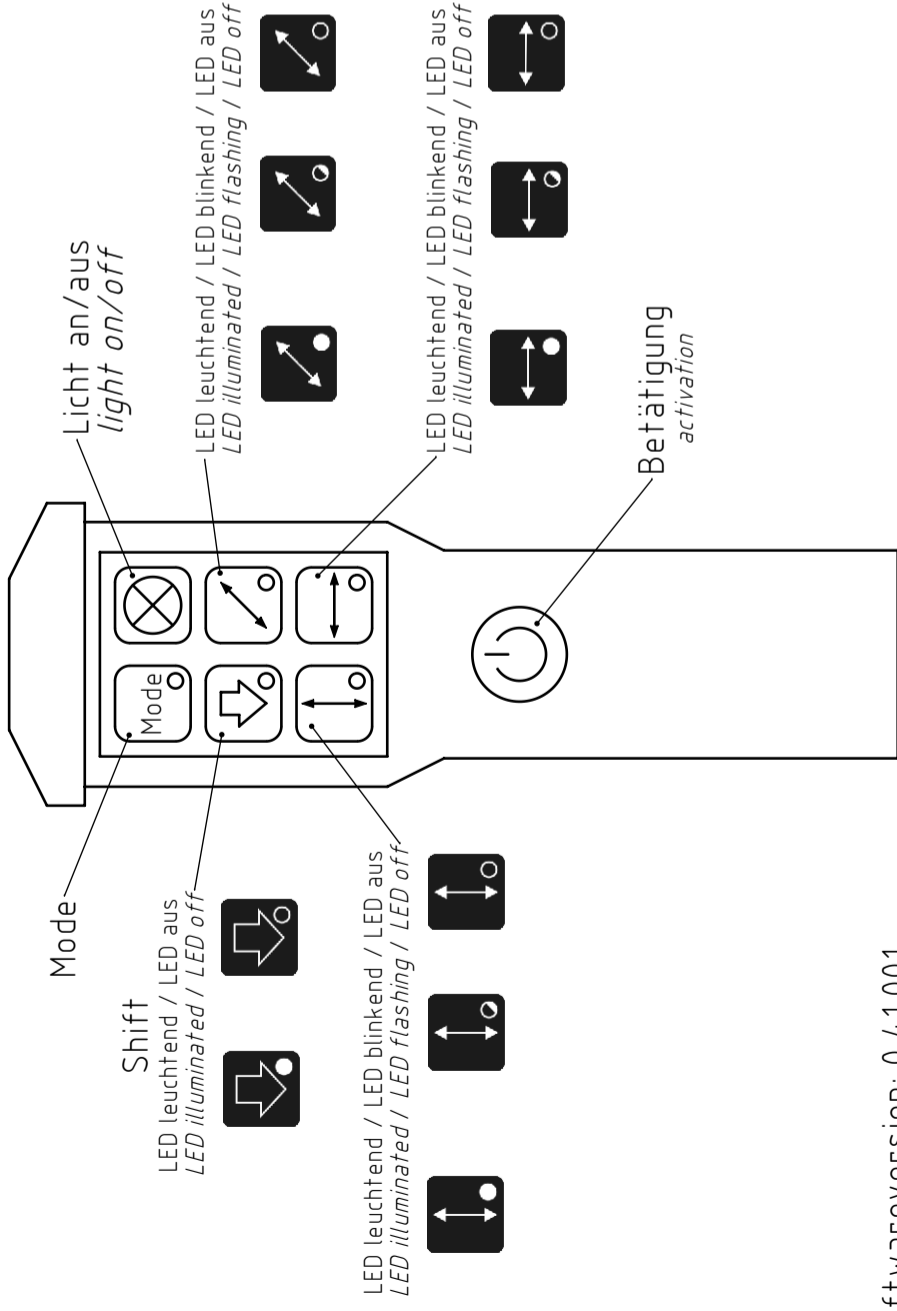
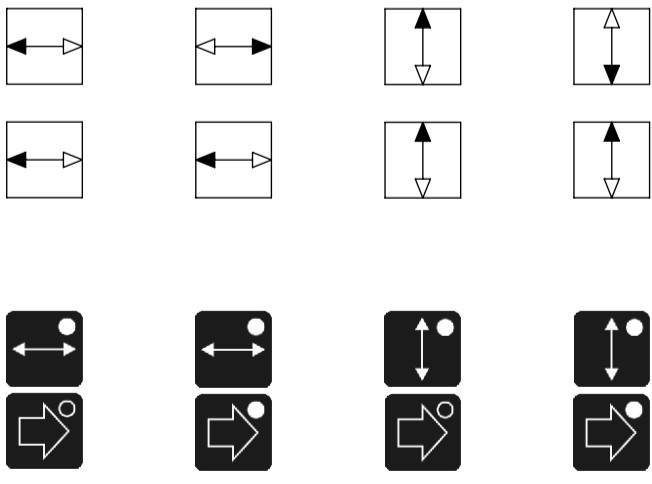

Kabelhandlampe

cable hand lamp

Vorwahl
preselection

C1

linke Platte / rechte Platte
left plate / right plate

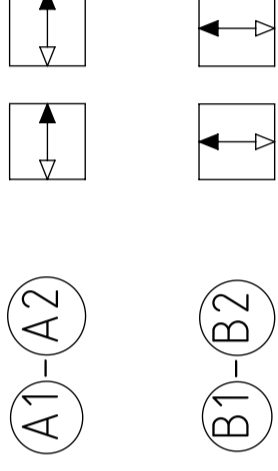

Vorwahl
preselection

C2

linke Platte / rechte Platte
left plate / right plate

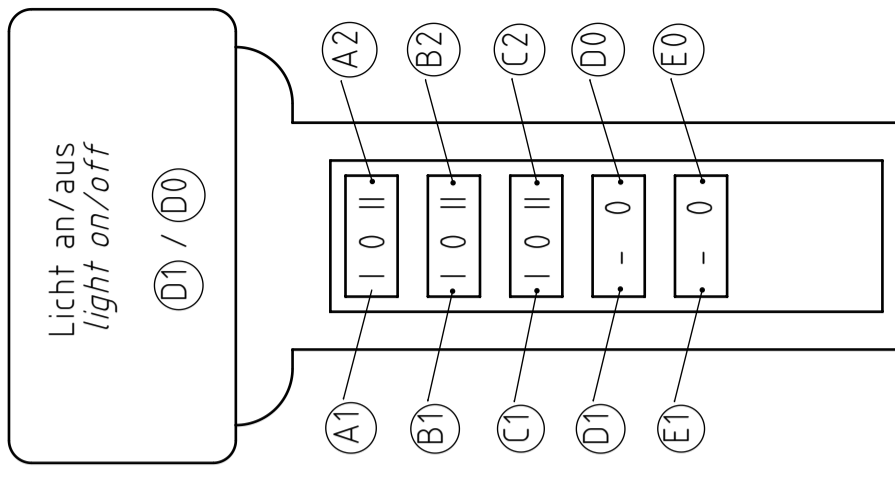
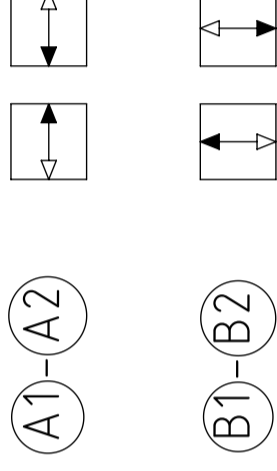

[6] PMS/LMS + VZ 985021

Size ISO 14405(E)

Schutzvermerk beachten
nach DIN ISO 16016

Allgemeintoleranzen
DIN ISO 2768-mK

Maßstab 1:1

Nettogewicht in kg 0.000

Dokumenttyp Fluid-Plan

Änderungsnr. 100075

Büro 300

Werkstoff

Werkstoffnummer

Mindeststreckgrenze Re in N/mm²

Mindeststreckgrenze Re in N/mm²

Mindeststreckgrenze Re in N/mm²

Mindeststreckgrenze Re in N/mm²

Mindeststreckgrenze Re in N/mm²

Mindeststreckgrenze Re in N/mm²

Mindeststreckgrenze Re in N/mm²



Fernbedienung PMS/LMS Bedienschema

Materialnummer 3000007	Revision 00	Dokumentnummer 10001022	Version 7	Blatt 10
Datum, Ersteller 02.09.2019 MOBERMAY	Datum, Prüfer 02.09.2019 MOBERMAY	Datum, Freigabe 02.09.2019 MOBERMAY	alte Materialnummer A3	

Softwareversion: 0.4.1.001

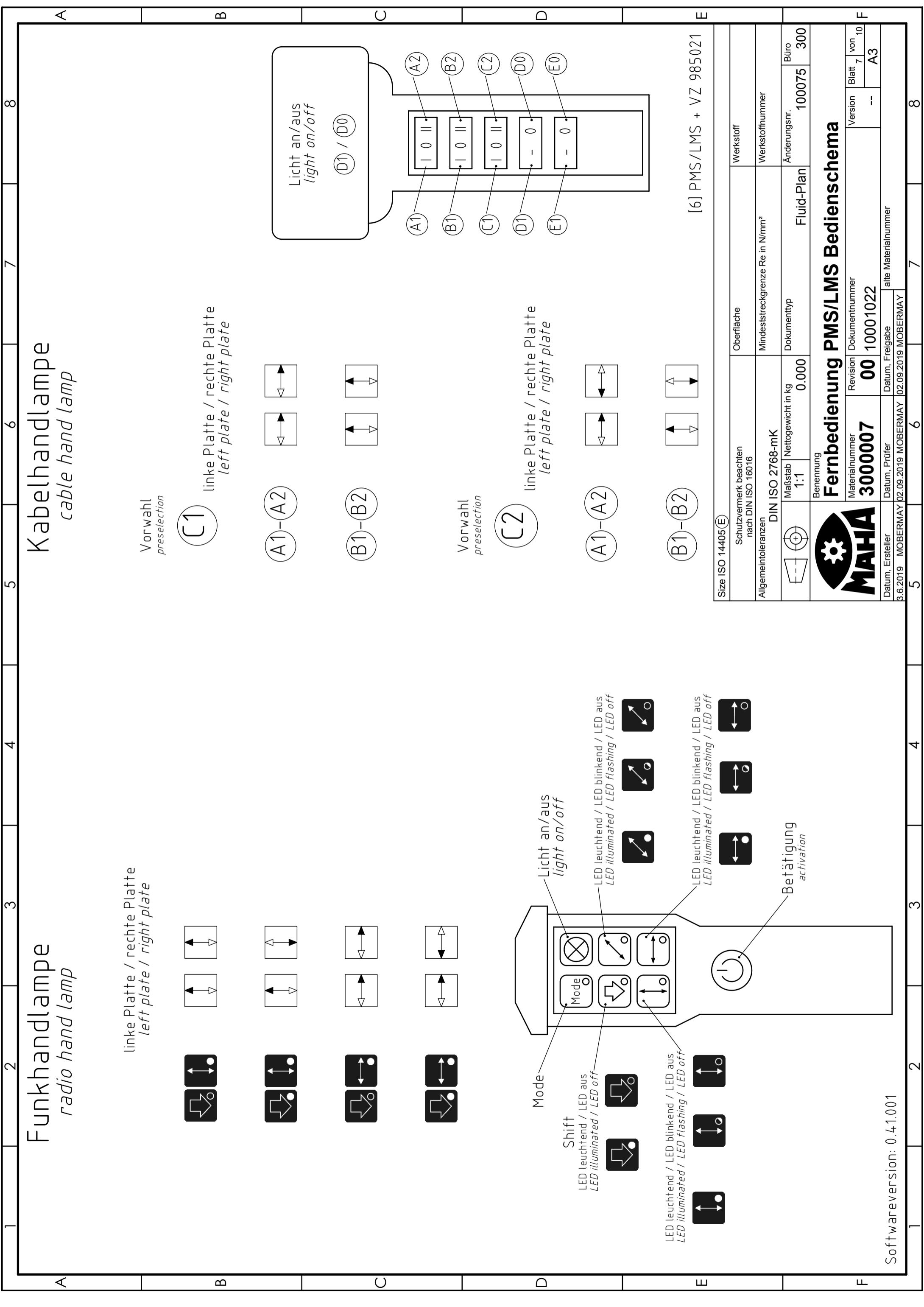

Funkhandlampe

radio hand lamp

linke Platte / rechte Platte
left plate / right plate

linke Platte / rechte Platte
left plate / right plate

linke Platte / rechte Platte
left plate / right plate

linke Platte / rechte Platte
left plate / right plate

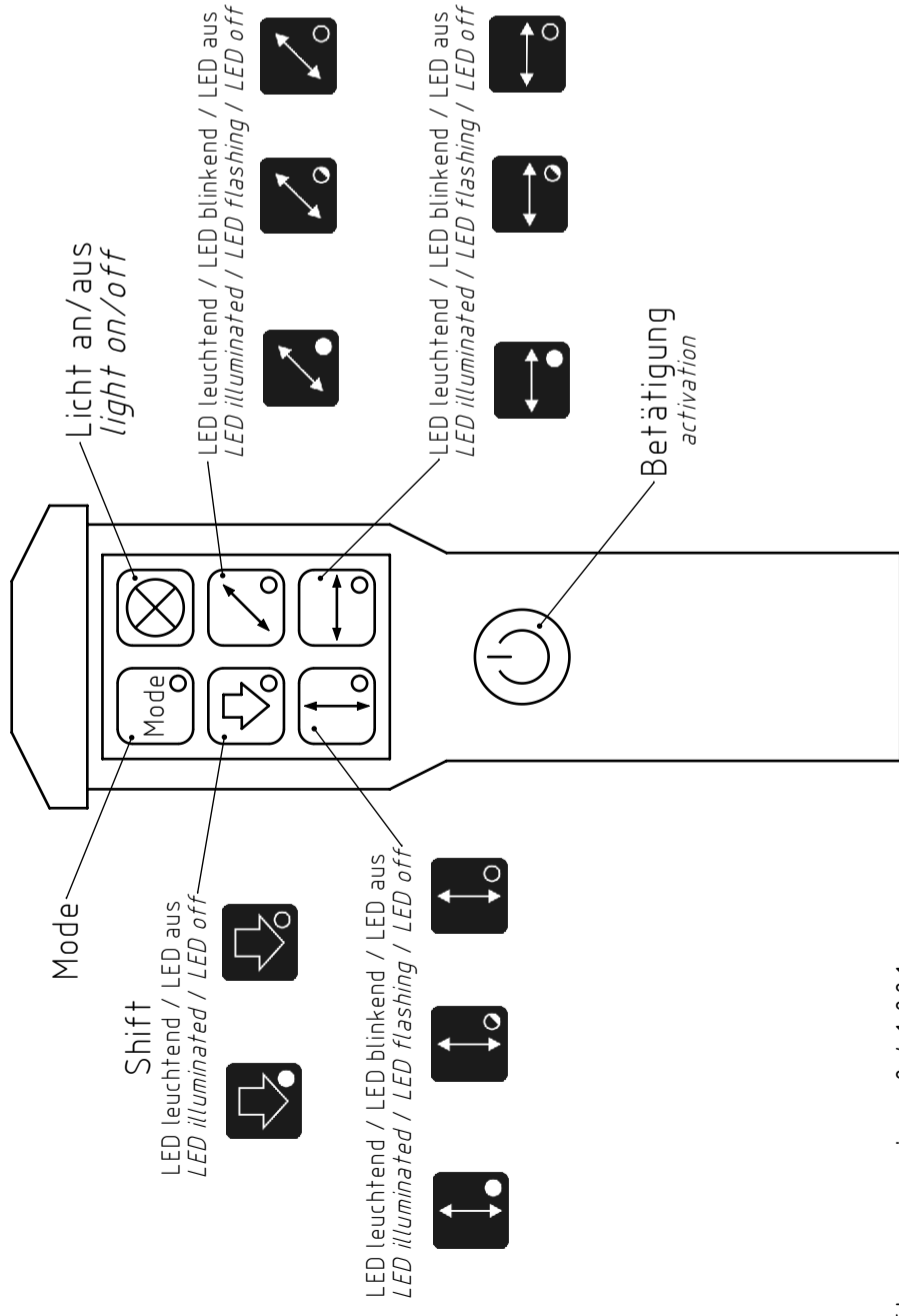
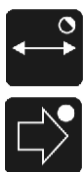

[7] PMS/LMS + VZ 985023 (Funk)

Size ISO 14405 (E)		Oberfläche		Werkstoff	
Schutzvermerk beachten nach DIN ISO 16016					
Allgemeintoleranzen		Mindeststreckgrenze Re in N/mm ²		Werkstoffnummer	
DIN ISO 2768-mK					
Maßstab		Nettogewicht in kg		Änderungsnr.	
1:1		0.000		Fluid-Plan 100075	
Büro		300			
Benennung					
Fernbedienung PMS/LMS Bedienschema					
Materialnummer		Revisionsnummer		Version	
3000007		00		8 10	
Datum, Prüfer		alte Materialnummer		Blatt	
02.09.2019 MOBERMAY		02.09.2019 MOBERMAY		-- A3	
MOBERMAY		MOBERMAY			

Kabelhandlampe cable hand lamp

Automatikmodus automatic mode

Vorwahl
preselection (C1) // Verfahrendauer 1 // travel duration 1 // Verfahrendauer 2 // travel duration 2 (C2)

Schalterstellung
switch position (E0)

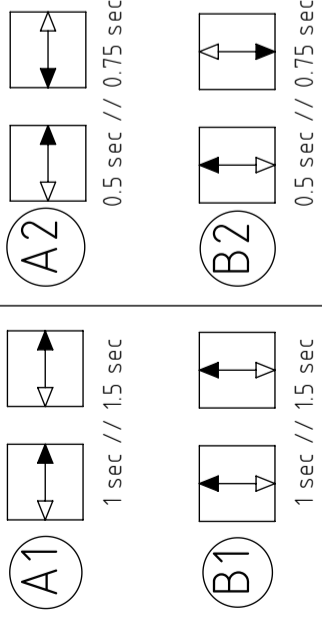

Schalterstellung
switch position (E1)

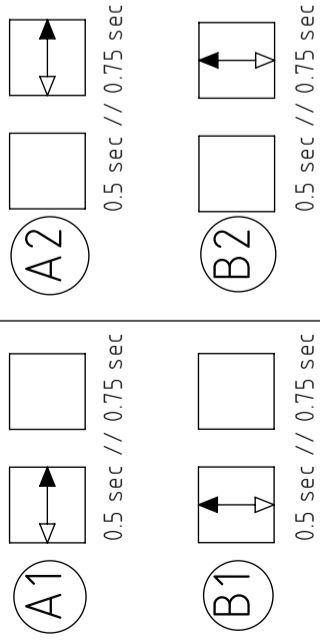

Manueller Modus manual mode

Schalterstellung
switch position (E1)

Vorwahl
preselection (C2)

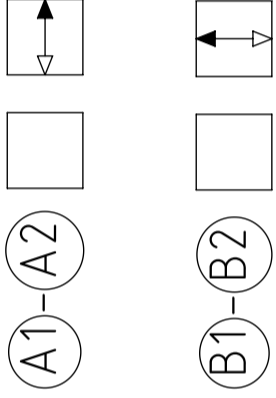

Vorwahl
preselection (C1)

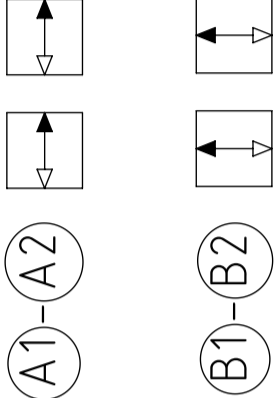

Schalterstellung
switch position (E0)

Vorwahl
preselection (C2)

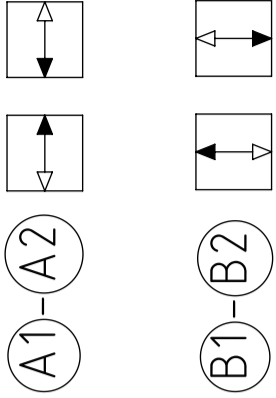

Vorwahl
preselection (C1)

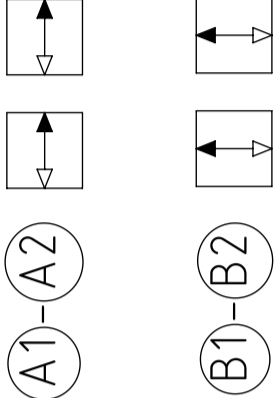

Umschalten zwischen Automatik- und manuellem Modus durch gleichzeitiges Drücken von (A1) und (B2)

Toggle between automatic and manual mode by pressing (A1) and (B2) simultaneously

[7] PMS/LMS + VZ 985023 (Kabel)

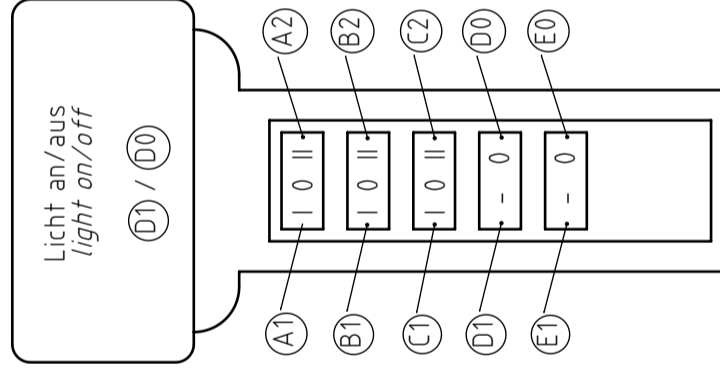

Size ISO 14405 (E)	Schutzvermerk beachten nach DIN ISO 16016	Oberfläche	Werkstoff
Allgemeintoleranzen	DIN ISO 2768-mK	Mindeststreckgrenze Re in N/mm ²	Werkstoffnummer
	Maßstab 1:1	Nettogewicht in kg 0.000	Dokumenttyp
			Änderungsnr. 100075
			Büro 300
Benennung			
Fernbedienung PMS/LMS Bedienschema			
Materialnummer	Revision	Dokumentnummer	Version
3000007	00	10001022	Blatt 9 von 10
Datum, Ersteller	Datum, Prüfer	alte Materialnummer	
3.6.2019 MOBERMAY	02.09.2019 MOBERMAY	02.09.2019 MOBERMAY	

Funkhandlampe

radio hand lamp

Kabelhandlampe

cable hand lamp

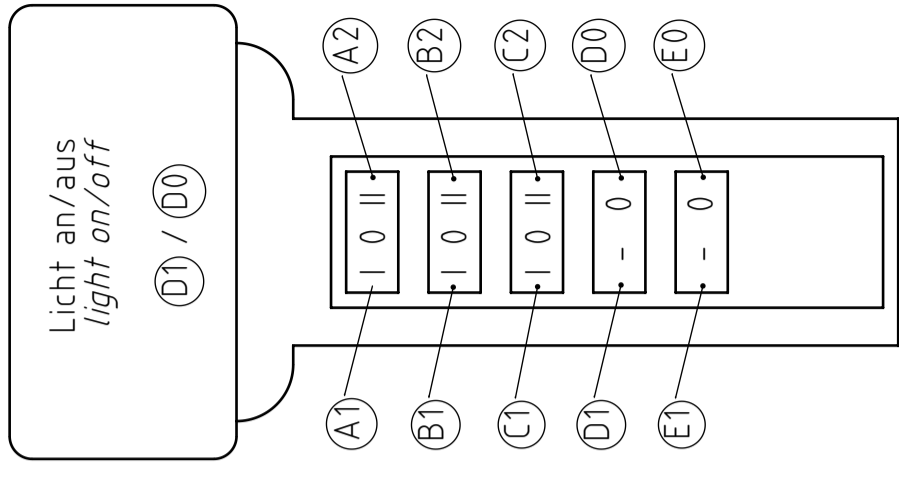
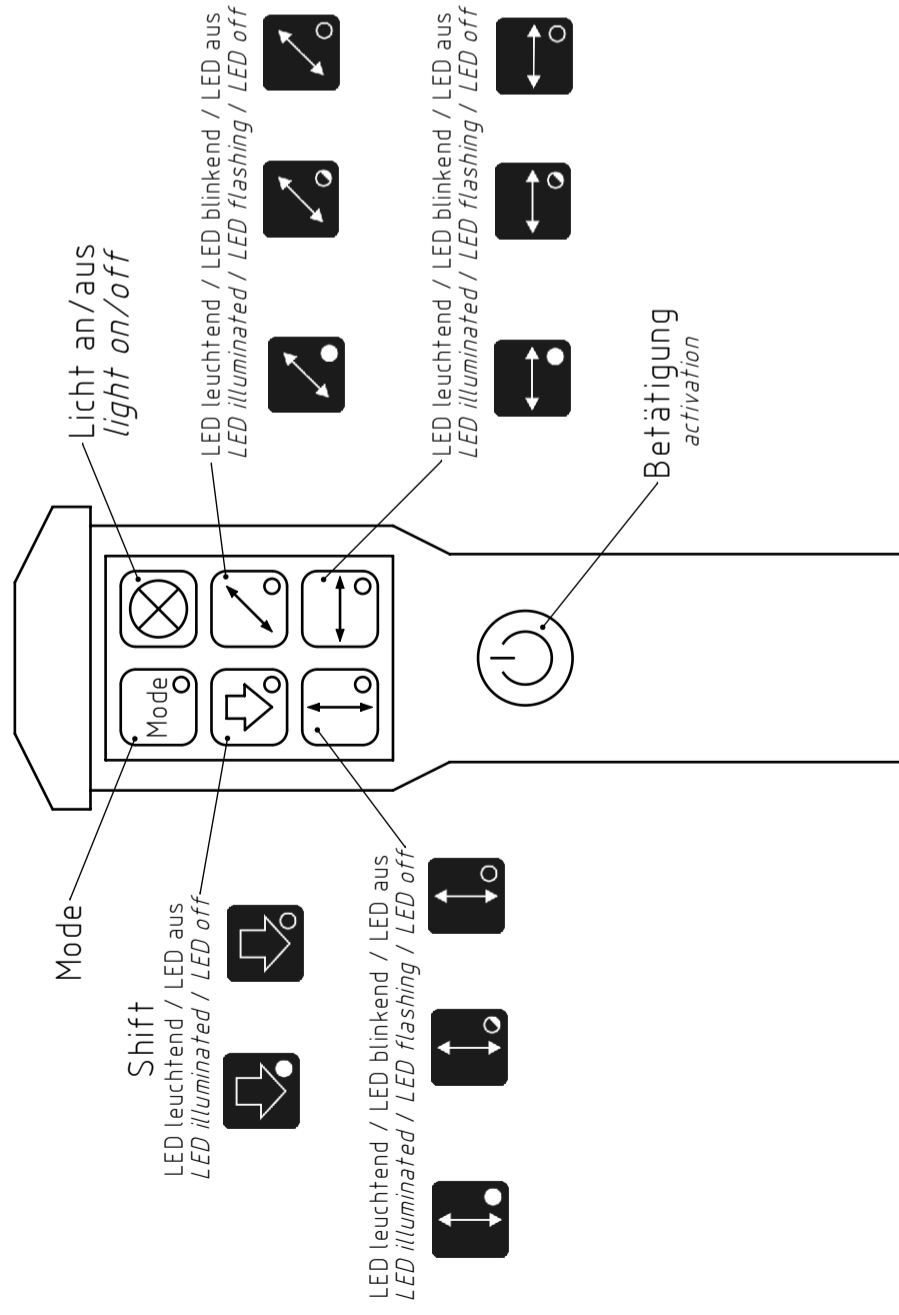
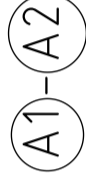

[A] PMS 3/P PIT

Size ISO 14405 (E)

Schutzvermerk beachten
nach DIN ISO 16016

Oberfläche

Werkstoff

Allgemeintoleranzen

Mindeststreckgrenze Re in N/mm²

Werkstoffnummer



DIN ISO 2768-mK

Dokumenttyp

Änderungsnr.

Maßstab 1:1

Nettogewicht in kg

Fluid-Plan

100075

300



Benennung
Fernbedienung PMS/LMS Bedienschema

Materialnummer

Revision

Dokumentnummer

Version

Blatt

alte Materialnummer

3000007

00

10001022

--

10

A3

Datum, Ersteller

Datum, Prüfer

alte Materialnummer

MOBERMAY

MOBERMAY

02.09.2019

02.09.2019

MOBERMAY

MOBERMAY

02.09.2019

02.09.2019

MOBERMAY

MOBERMAY

02.09.2019

02.09.2019

MOBERMAY

MOBERMAY

02.09.2019

02.09.2019

MOBERMAY

MOBERMAY

02.09.2019

02.09.2019

MOBERMAY

MOBERMAY

02.09.2019

02.09.2019

MOBERMAY

MOBERMAY

02.09.2019

02.09.2019

MOBERMAY

MOBERMAY

02.09.2019

02.09.2019

MOBERMAY

MOBERMAY

02.09.2019

02.09.2019

MOBERMAY

MOBERMAY

02.09.2019

02.09.2019

MOBERMAY

MOBERMAY

02.09.2019

02.09.2019

MOBERMAY

MOBERMAY

02.09.2019

02.09.2019

MOBERMAY

MOBERMAY

02.09.2019

02.09.2019

MOBERMAY

MOBERMAY

02.09.2019

02.09.2019

MOBERMAY

MOBERMAY

02.09.2019

02.09.2019

MOBERMAY

MOBERMAY

02.09.2019

02.09.2019

MOBERMAY

MOBERMAY

02.09.2019

02.09.2019

MOBERMAY

MOBERMAY

02.09.2019

02.09.2019

MOBERMAY

MOBERMAY

02.09.2019

02.09.2019

MOBERMAY

MOBERMAY

02.09.2019

02.09.2019

MOBERMAY

MOBERMAY

02.09.2019

02.09.2019

MOBERMAY

MOBERMAY

02.09.2019

02.09.2019

MOBERMAY

MOBERMAY

02.09.2019

02.09.2019

MOBERMAY

MOBERMAY

02.09.2019

02.09.2019

MOBERMAY

MOBERMAY

02.09.2019

02.09.2019

MOBERMAY

MOBERMAY

02.09.2019

02.09.2019

MOBERMAY

MOBERMAY

02.09.2019

02.09.2019

MOBERMAY

MOBERMAY

02.09.2019

02.09.2019

MOBERMAY

MOBERMAY

02.09.2019

02.09.2019

MOBERMAY

MOBERMAY

02.09.2019

02.09.2019

MOBERMAY

MOBERMAY

02.09.2019

02.09.2019

MOBERMAY

MOBERMAY

02.09.2019

02.09.2019

MOBERMAY

MOBERMAY

02.09.2019

02.09.2019

MOBERMAY

MOBERMAY

02.09.2019

02.09.2019

MOBERMAY

MOBERMAY

02.09.2019

02.09.2019

MOBERMAY

MOBERMAY

02.09.2019

02.09.2019

MOBERMAY

MOBERMAY

02.09.2019

02.09.2019

MOBERMAY

MOBERMAY

02.09.2019

02.09.2019

MOBERMAY

MOBERMAY

02.09.2019

02.09.2019

MOBERMAY

MOBERMAY

02.09.2019

02.09.2019

MOBERMAY

MOBERMAY

02.09.2019

02.09.2019

MOBERMAY

MOBERMAY

02.09.2019

02.09.2019

MOBERMAY

MOBERMAY

02.09.2019

02.09.2019

MOBERMAY

MOBERMAY

02.09.2019

02.09.2019

MOBERMAY

MOBERMAY

02.09.2019

02.09.2019

MOBERMAY

MOBERMAY

02.09.2019

02.09.2019

MOBERMAY

MOBERMAY

02.09.2019

02.09.2019

MOBERMAY

MOBERMAY

02.09.2019

02.09.2019

MOBERMAY

MOBERMAY

02.09.2019

02.09.2019

MOBERMAY

MOBERMAY

02.09.2019

02.09.2019

MOBERMAY

MOBERMAY

02.09.2019

02.09.2019

MOBERMAY

MOBERMAY

02.09.2019

02.09.2019

MOBERMAY

MOBERMAY

02.09.2019

02.09.2019

MOBERMAY

MOBERMAY

02.09.2019

02.09.2019

MOBERMAY

MOBERMAY

02.09.2019

02.09.2019

MOBERMAY

MOBERMAY

02.09.2019

02.09.2019

MOBERMAY

MOBERMAY

02.09.2019

02.09.2019

MOBERMAY

MOBERMAY

02.09.2019

02.09.2019

MOBERMAY

MOBERMAY

02.09.2019

02.09.2019

MOBERMAY

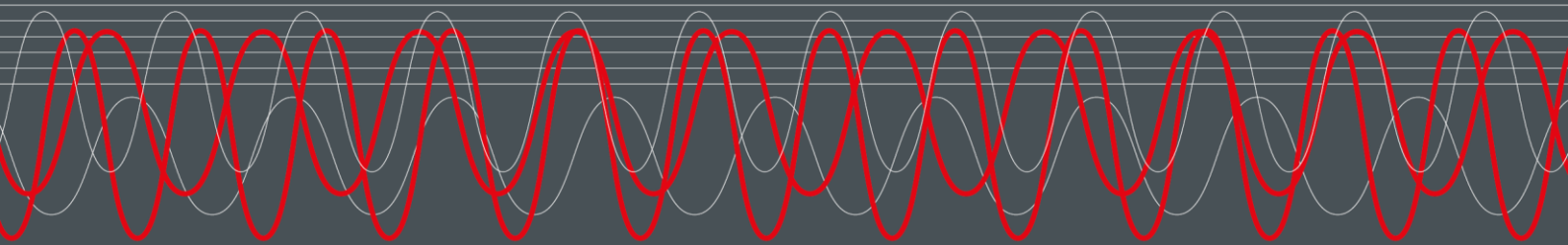

MAHA MASCHINENBAU HALDENWANG GMBH & CO. KG

Hoyen 20
87490 Haldenwang
Germany

☎ +49 8374 585 0
✉ maha@maha.de
🌐 maha.de